

Quarter Master Series 94 Actuator



Installation, Operation and Maintenance Manual



Table of Contents

Series 94 Electric Actuator Introduction	3
Description	3
Electrical Requirement	3
Installation.....	4
Electrical.....	4
Type 21 Ball Valve	4
Type 23 Ball Valve (3-way)	5
Type 57/57L Butterfly Valves	5
Actuator Mounting Dimensions.....	6
Operation	7
Manual Override Operation	7
Setting Limit Switches	7
Options.....	8
Single Limit Switch.....	8
Double Limit Switch	8
Heater and Thermostat.....	9
RHM	9
Mechanical Brake	9
Feedback Potentiometer.....	9
Series 94 Options Codes for Serial # Tags.....	10
Troubleshooting.....	11
Maintenance	13
Spare Parts	13

Series 94 Electric Actuator Introduction

Description

The Series 94 electric actuators feature a reversing, capacitor run motor, with a permanently lubricated gear train. These actuators are equipped with integral thermal overload protection (AC models) with automatic reset, independently adjustable limit switches, declutchable manual override, position indicator, Zytel FR50 housing with stainless steel trim, ISO bolt circle, and 2 (two) ½” NPT conduit entries.

Standard models are offered in 120 VAC, feature a Nema Type 4X enclosure, and provide up to 300 in/lbs of output torque.

Various options are available such as operating voltages, additional limit switches, heater and thermostat, feedback potentiometers, etc. Please see page 8 regarding these options.

Electrical Requirement

CAUTION: Proper voltage must be supplied to actuator or damage will result.



CAUTION: If 120vac & 220vac models are PLC driven, output contacts of PLC should be rated at a minimum of 1.5 times required input voltage of actuator

NOTE: To conform to various electrical codes, **a green grounding screw** has been installed (on the baseplate) inside of actuator.

Terminal Strip Wiring: 75° C Copper Supply Wires up to #14 AWG, wired as per the attached diagrams or the wiring diagram affixed inside of actuator cover. Control Wiring shall be insulated with conductors rated 105° C, 300V minimum. Torque Terminal Strip wiring to 5 in/lbs.

Model	120 Vac			220 Vac		12 Vdc		24 Vdc		12 Vac		24 Vac		Cycle Time per 90 Degrees (Seconds)	Weight (lbs)
	Torque (in/lbs)	Amp Draw	Duty Cycle	Amp Draw	Duty Cycle	Amp Draw	Duty Cycle	Amp Draw	Duty Cycle	Amp Draw	Duty Cycle	Amp Draw	Duty Cycle		
A94	150	0.5	100%	0.4	100%	2.0	75%	4.0	75%	2.0	75%	4.0	75%	5	3.5
B94	300	0.8	75%	0.6	75%	2.0	75%	4.0	75%	2.0	75%	4.0	75%	5	3.5

Note: Amp rating is considered locked rotor
Duty cycles are for ambient temperature (73° F)

Installation

Electrical **Reference Drawing #279QM**

1. To gain access to terminal strip (Part #8 & 9) it is necessary to remove manual override handle (Part #34) by loosening slotted setscrew (Part #35). Remove 8 cover screws and cover.
2. Make electrical connections to terminal strip as shown on wiring schematic located inside the cover (per various electrical codes there is a green screw on the actuator base plate for grounding purposes). Terminals are suitable for up to #14 AWG wire. All units are completely calibrated prior to shipment, and no internal adjustments should be required.
3. Install 1/2" NPT conduit fitting(s) to actuator base.

Note: Proper conduit fitting must be used to maintain NEMA Type 4X enclosure rating

NOTE: We recommend sealing conduit openings on units installed outdoors or exposed to large temperature swings (15°F or more).

We also recommend the heater and thermostat option in these applications.

4. Replace actuator (gasket if removed) cover, and install 8 cap screws supplied and tighten securely. For outdoor or wet locations it is recommended prior to replacing the cover that the top shaft seal be cleaned and coated with silicone grease. Also clean shaft and lightly coat seal area of shaft with silicone grease. Unit is now ready for operation.

Type 21 Ball Valve

Position the valve and the actuator to corresponding positions (either OPEN or CLOSED). The flats on the actuator shaft extension indicate valve position

Type 21 Ball Valves (See Drawing #0106BV sizes ½" – 2")

Install mounting bracket #3 to actuator #2 using bolts #8 and washers #9. Insert coupling #4 on stem of valve #1 and then bolt valve #1 to mounting bracket #3 using bolts #5, nuts #7, and washers #6.

Note: All bolts should be snug and not excessively over tightened.

Type 21 Ball Valves (See Drawing #0112BV sizes 2-1/2" - 3")

Install mounting bracket #3 to actuator #2 using bolts #8 and washers #9. Insert coupling #4 on stem of valve #1 and then bolt valve #1 to mounting bracket #3 using bolts #5, nuts #7, and washers #6.

Note: All bolts should be snug and not excessively over tightened.

Type 23 Ball Valve (3-way)

Position the valve and the actuator to corresponding positions (either OPEN or CLOSED). The flats on the actuator shaft extension indicate valve position

Type 23 Ball Valves (3-way): (See Drawing #0129BV, sizes ½" - 3")

Install mounting bracket #3 to actuator #2 using bolts #8 and washers #9. Insert coupling #4 on stem of valve #1 and then bolt valve #1 to mounting bracket #3 using bolts #5, nuts #7, and washers #6.

Type 57/57L Butterfly Valves

CAUTION: If valve is in line, system must be shut down and have no line pressure before removing throttle plate and retaining washer.

Position the valve and the actuator to corresponding positions (either OPEN or CLOSED). The flats on the actuator shaft extension indicate valve position

Butterfly Valves (See Drawing # 0203BF57 sizes 1-1/2" - 4")

No specially machined stem or valve body drilling required. Remove handle (remove handle cap and hex head bolt) to expose throttle plate screws. Remove throttle plate and retaining washer to expose existing bolt pattern.

Mount bracket #3 to actuator #2 with bolts #8 and washers #9 and tighten evenly. Insert coupling #4 into actuator #2. Install valve #1 onto mounting bracket #3 and align stem of valve to engage with coupling. (Line scribed on top of stem indicates disc orientation). Install bolts #5, washers #6 and nuts #7 and tighten evenly.



CAUTION: If mounted unit is installed other than straight up, the actuator should be supported independently to prevent side loading and loosening up of fasteners.

Actuator Mounting Dimensions

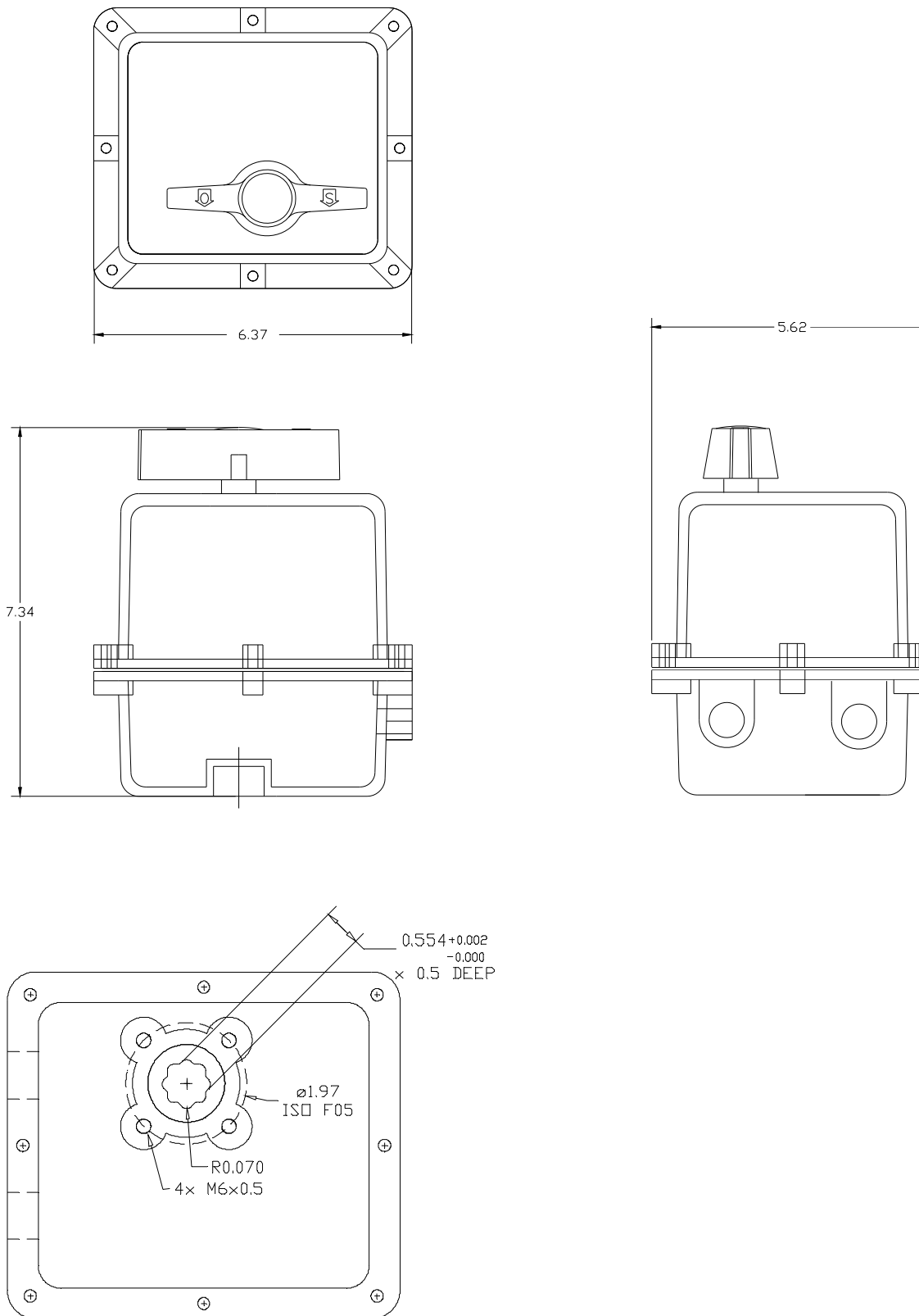

Operation

Manual Override Operation Reference Drawing #279QM

Push down on handle (Part #34) and rotate within labeled limits.
To re-engage simply rotate actuator handle in opposite direction until it moves up and re-engages.

CAUTION: The manual override should only be used when there is no power applied to actuator. When power is restored the actuator will automatically resume normal operation.

Setting Limit Switches Reference Drawing #279QM



Disconnect power!

Open Travel Limit Switch (SW-2 Part #14):

Using declutchable manual override, move the valve into a full open position. Then loosen set screws on top cam (Part #21) and rotate cam (CCW) into limit switch arm until a click is heard, this designates the switch circuit has opened and defines a full open position. Tighten 2 set screws (Part #22) on cam.

Close Travel Limit Switch (SW-1 Part #14):

Using declutchable manual override, move the valve to a full closed position, loosen set screws on bottom cam (Part #21) and rotate cam (CW) into limit switch arm until a click is heard, this designates the switch circuit has opened and defines a full closed position. Tighten 2 set screws (Part #22) on cam.

Manually position valve to midstroke. Reapply power to actuator and drive to open or closed position. Actuator motor will run. The shaft will not turn until drive pins (Part #7) reseat in drive gear. This could take up to 10 seconds.

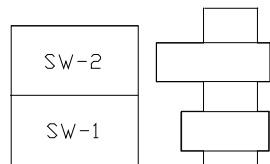

SW-2 OPEN TRAVEL SWITCH

SW-1 CLOSE TRAVEL SWITCH

Options

Models A94 & B94

Single Limit Switch

Install additional limit switch directly on top of standard limit switches using screws provided.

Wiring for SW-3 is as follows:

- Pink = Common to Terminal #6
- Purple = NC to Terminal #7
- Blue = NO to Terminal #8

Cam must be set so that this switch is tripped just ahead of Closed limit switch.

Wire tie loose wiring and check operation before installing cover.

Double Limit Switch

Installation and wiring is the same as for the single limit switch, with the addition of wiring for SW-4 as follows:

- Brown = Common to Terminal #9
- Green = NC to Terminal #10
- Orange = NO to Terminal #11

Cam must be set so that this switch is tripped just ahead of Open limit switch.

Wire tie loose wiring and check operation before installing cover.

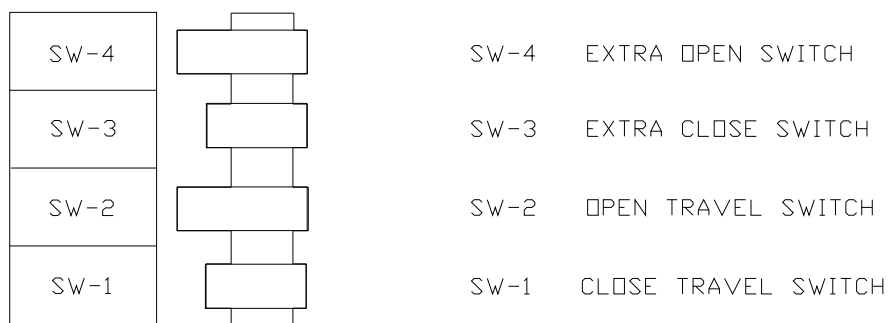

Heater and Thermostat

Install Heater into threaded hole located on actuator base plate.

Wiring is as follows:

Heater lead = Terminal #12

Thermostat lead = Terminal #13

Wire tie loose wiring and check operation before installing cover.

RHM

Reference Appropriate Drawing Number:

M00EL9903 - x92RHM 12vac & 24vac

M00EL9904 - x92RHM 12vdc & 24vdc

M00EL9905 - x92RHM 120vac & 220vac

The RHM is a combination heater and thermostat, and 2-SPDT dry contacts for the open and closed positions. Its best feature is to provide a means of powering the heater and thermostat without the need of additional wiring. When the actuator reaches end of travel, the NO contact on the travel switch is tripped, and provides power for optional light indication. At the same time, the appropriate relay is triggered providing dry contact position indication as well as powering the heater and thermostat. The heater and thermostat are not powered during travel, only at the end of travel. These units are easily identified with "RHM" in the model number; A94RHMW as an example.

Mechanical Brake

Loosen two (2) motor screws diagonally from each other and install bracket with tabs facing upward. Tighten screws

Install hexagonal adapter over armature shaft and tighten set screws.

NOTE: The adapter should be resting on the step of the armature shaft.

Install brake assembly onto hexagonal adapter making sure that the brake assembly is sitting flush on the bracket. Tighten with supplied screws.

Remove motor leads "A" & "B" from capacitor and install "piggy back connectors to capacitor, the re-install motor leads to their original locations.

Connect brake leads to piggy back connectors on capacitor (orientation does not matter)

Wire tie loose wiring and check operation before installing cover.

Feedback Potentiometer

Install drive gear face up over output shaft.

Install potentiometer and bracket on to base plate with potentiometer gear facing output shaft.

Wiring for potentiometer as follows:

#1 on potentiometer (white w/black stripe)	#16 on terminal strip.
#2 on potentiometer (grey)	#15 on terminal strip.
#3 on potentiometer (brown w/white stripe)	#14 on terminal strip.

Using multimeter set at 2k ohms, calibrate potentiometer with leads from meter connected to terminals #15 and #16. With actuator in closed position multimeter should read between 95 and 100 ohms.

Rotate actuator 90 degrees (open position).

Connect leads from multimeter to terminal #14 and #15; multimeter should read 95 to 100 ohms. If necessary adjust open limit switch cam so that multimeter will read 95-100 ohms.

Series 94 Options Codes for Serial # Tags

M1	1 extra limit switch
M2	2 extra limit switches
HT	Heater & thermostat
RHM	RHM Module
P	Feedback potentiometer
C1	4-20 mA Positioner
M	Mechanical brake
CO	Center off
CLC	Cycle length control
2WC	2-wire control
FS	Failsafe Battery Pak
C3	4-20mA Output Transducer

Example 1: **A94HTPW**

Heater & thermostat and feedback potentiometer installed.

Example 2: **AM94RHMW**

Mechanical brake and RHM Module installed.

Troubleshooting

Q: *What if there is no output, but the motor runs?*

A: Manual override possibly engaged.

When the manual override is engaged, the motor will run, but no output will be observed until the manual override re-engages with the output shaft.

A: Valve stem broken. When the valve stem is broken, there will not be a change in fluid movement, making it seem as if the actuator has no output.

Q: *What if valve does not cycle?*

A: No power source to actuator. Check for power.

A: Power source disconnected. Check for broken wire, loose connection or no connection as per appropriate wiring diagram.

A: Low or wrong power source. Check for proper voltage.

A: Mechanical Brake jammed or misaligned. Check alignment of brake assembly.

This could occur during installation when someone would rest their hand on the Mechanical Brake to steady themselves.

Q: *What if there is water and/or moisture inside of the unit?*

A: Conduit fitting installed improperly. Re-install correctly.

A: Cover and/or base seal damaged. Replace damaged seal(s).

A: Base gasket damaged or installed improperly. Check gasket and replace if necessary.

A: Temperature swings of more than 15 degrees F. Install heater and thermostat to eliminate condensation.

When these temperature swings occur, the unit will “sweat” on the inside causing internal corrosion unless the actuator is equipped with a heater and thermostat to keep a constant temperature inside of the housing.

A: Unit has been submerged. Raise unit above liquid level.

An actuator that is to be submerged MUST meet NEMA Type 6 for the proper protection of the actuator and the elimination of a potential hazard. We do not recommend submerging the Series 94 Actuator as the electrical rating does not meet NEMA 6.

Q: *What if unit is oscillating?*

A: Valve torque exceeds output torque of actuator. Check for chemical compatibility of valve, and flange torque.

Q: *What if thermal overload frequently cuts out motor?*

A: Frequency of operation exceeds duty cycle rating. Check cycling period.

A: Unit is oscillating. Refer to above.

Q: *What if motor hums and no output is observed?*

A: Foreign material caught in valve. Remove material and inspect valve for damaged and/or worn parts. Replace parts as necessary.

A: Unit wired incorrectly (simultaneously powering open and closed). Check wiring as per appropriate wiring diagram.

A: Capacitor worn. Replace.

Q: *What if actuator “over-shoots” limit switches without stopping?*

A: Actuator wired in parallel to each other. Please note that each actuator requires it's own set of switch contacts.

Maintenance

Disconnect power!



NEVER REMOVE ACTUATOR COVER WHILE CIRCUITS ARE LIVE!

CAUTION: It is imperative for reducing the chance of electrical shock, and to prevent ignition of hazardous atmospheres that you

Disconnect power

before any maintenance or repairs are performed.

Series 94 actuators are virtually maintenance free. We do however, recommend that periodic checks are made to ensure that all fasteners are tight and properly torqued to extend the life of the actuator and valve.

Series 94 Actuators are manufactured with factory lubricated grease in the gear case and gearbox. This lubricant should never have to be replenished.

For outdoor or wet locations keep top and bottom seals coated with a silicone based grease.

Spare Parts

Reference Drawing #279QM

We recommend that the following be kept on hand as spare parts.

1 --- Limit Switch (Part #14)

1 --- Capacitor (Part #13)

NOTE: When ordering replacement motor parts and/or options specify model # and voltage.

Attachments:

12 drawings: 296S92, 295S92, 297S92, 7403119, 0106BV, 0112BV, 0129BV, 0203BF, 279QM, M00EL9903, M00EL9904, M00EL9905

WIRING DIAGRAM FOR 115 VAC AND 220 VAC ONLY

ACTUATOR SHOWN IN COUNTER-CLOCKWISE EXTREME OF TRAVEL, OR "OPEN" POSITION

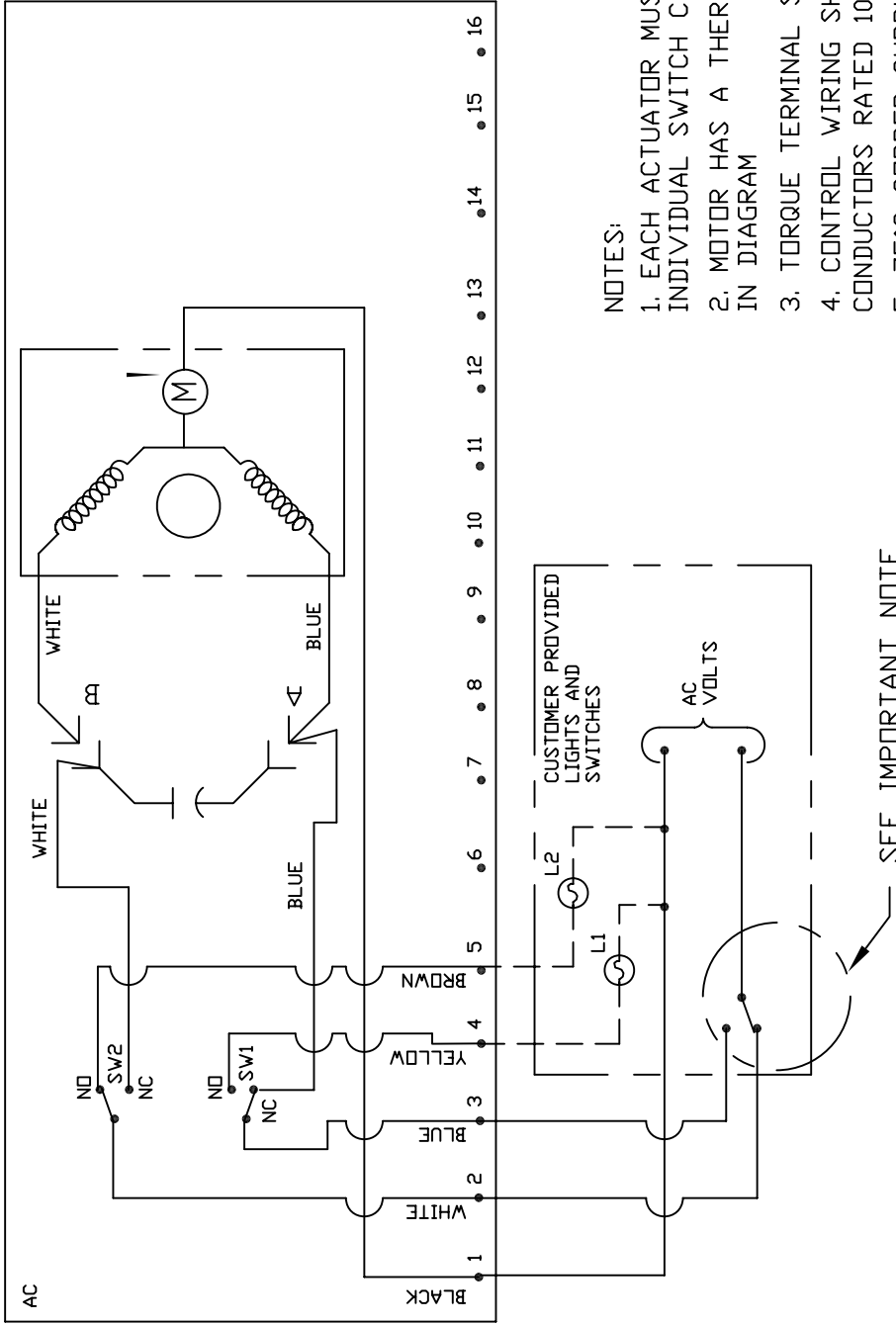

NOTES:

1. EACH ACTUATOR MUST BE POWERED THRU ITS OWN INDIVIDUAL SWITCH CONTACTS TO AVOID CROSS FEED
2. MOTOR HAS A THERMAL PROTECTOR AS SHOWN BY (M) IN DIAGRAM
3. TORQUE TERMINAL STRIP WIRING TO 5 IN-LBS.
4. CONTROL WIRING SHALL BE INSULATED WITH CONDUCTORS RATED 105°C, 300V MINIMUM.
5. 75°C COPPER SUPPLY WIRES ONLY.

ASAHI/AMERICA

ISO 9001 CERTIFIED
35 GREEN STREET, P.O. BOX 653, MALDEN, MA.

THIS DRAWING AND ALL INFORMATION HEREON IS THE PROPERTY OF ASAHI/AMERICA. ANY COPYING, REPRODUCTION OR UNAUTHORIZED USE IS FORBIDDEN WITHOUT WRITTEN CONSENT.

SERIES 94 WIRING DIAGRAM
120/220 VAC

NAME	DATE
DR JOHN GLASSFORD	6/18/07
APPD DAVE HURLEY	6/18/07
PROD LEO LESTER	6/19/07
WO#/SO#	
FILE ACAD11\S92	

SIZE A	DWG. NO. 296S92	REV C
SCALE NTS	SHEET 1	OF 1



ACTUATOR SHOWN IN COUNTER CLOCKWISE EXTREME
OF TRAVEL OR "OPEN" POSITION

DC WIRING DIAGRAM

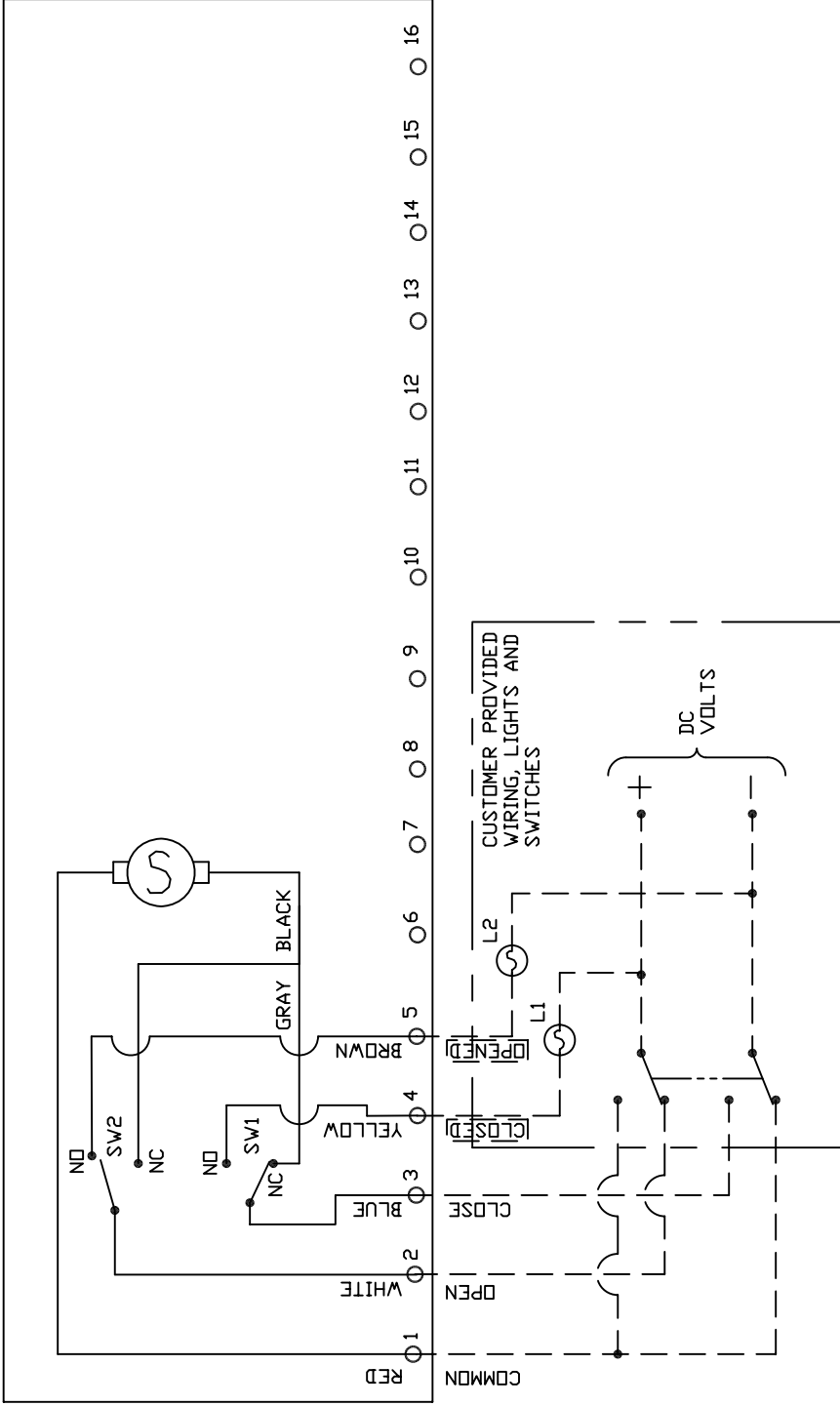

QUATER MASTER - 94
DC WIRING DIAGRAM

SIZE	A	DWG. NO.	295S92	REV	C
SCALE	NTS			SHEET 1	OF 1

THIS DRAWING AND ALL INFORMATION
HEREON IS THE PROPERTY OF
ASAHI/AMERICA. ANY COPYING,
REPRODUCTION OR UNAUTHORIZED USE
IS FORBIDDEN WITHOUT WRITTEN
CONSENT.

NAME	DATE
DR JOHN GLASSFORD	6/18/07
APPD DAVE HURLEY	6/18/07
PROD LEO LESTER	6/19/07
WO#/SO#	
FILE	ACAD11\S92

NOTES:

1. TORQUE TERMINAL STRIP WIRING TO 5 IN-LBS.
2. CONTROL WIRING SHALL BE INSULATED WITH CONDUCTORS RATED 105°C, 300V MINIMUM.
3. 75°C COPPER SUPPLY WIRES ONLY.

WIRING DIAGRAM FOR 12 OR 24VAC ONLY
ACTUATOR SHOWN IN COUNTER-CLOCKWISE EXTREME OF TRAVEL, OR "OPEN" POSITION

ACTUATOR SERIES 92\94

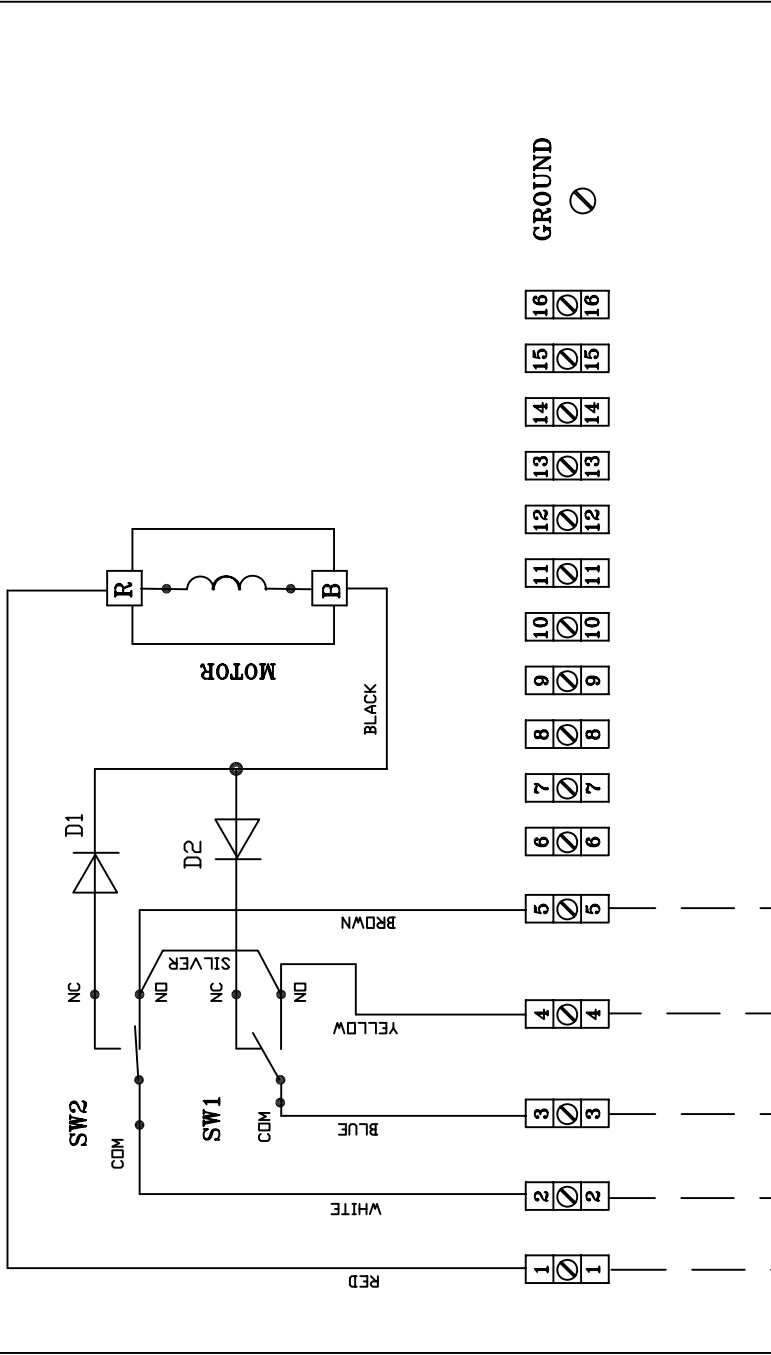

NOTES:

1. EACH ACTUATOR MUST BE POWERED THRU ITS OWN INDIVIDUAL SWITCH CONTACTS TO AVOID CROSS FEED
2. MOTOR LEADS ARE REVERSED FOR 1100 & 2000 IN/LB ACTUATOR

SWITCH LOCATION VIEWED FROM TERMINAL STRIP FRONT

SW-2 - OPEN
SW-1 - CLOSE

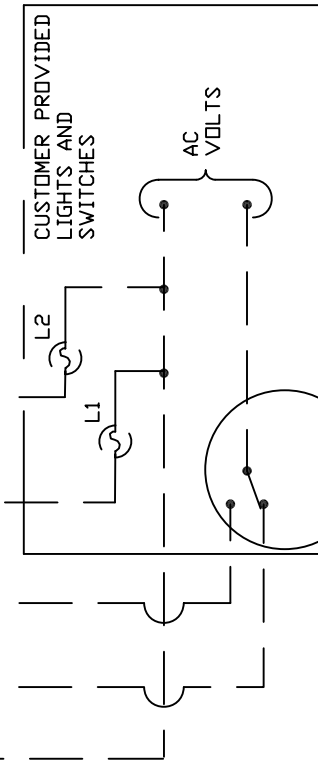

ASAHI/AMERICA
ISO 9001 CERTIFIED
35 GREEN STREET, P.O. BOX 653, MALDEN, MA.

THIS DRAWING AND ALL INFORMATION HEREON IS THE PROPERTY OF ASAHI/AMERICA. ANY COPYING, REPRODUCTION OR UNAUTHORIZED USE IS FORBIDDEN WITHOUT WRITTEN CONSENT.

NAME	DATE
DR J.GLASSFORD	5/26/06
APPD K.BLYSTONE	5/26/06
PROD	
WO#/SO#	
FILE	

SERIES 92/94 12/24 VAC
WIRING DIAGRAM

SIZE A	DWG. NO. 7403119	REV A
SCALE NTS	SHEET 1	OF 1



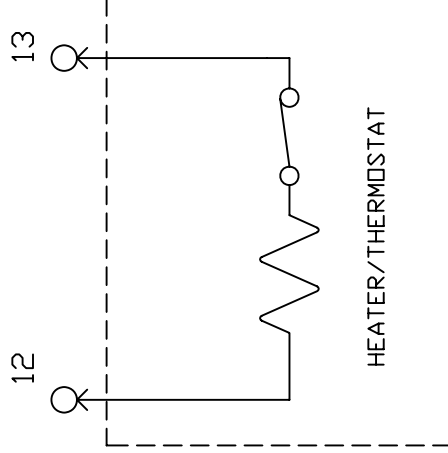
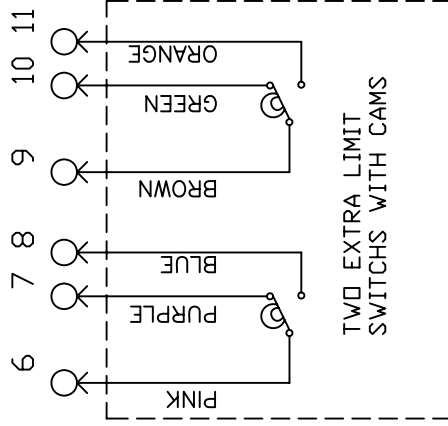
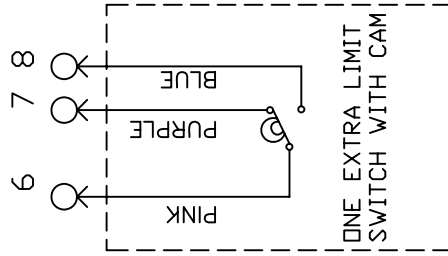
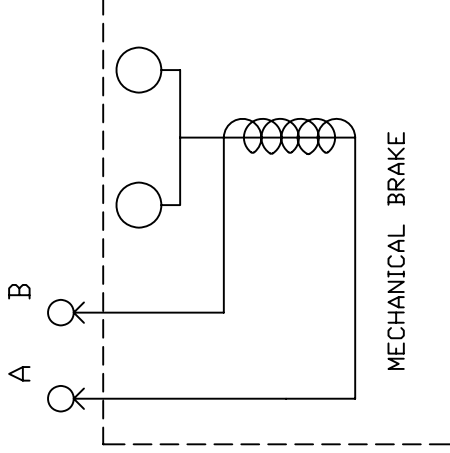
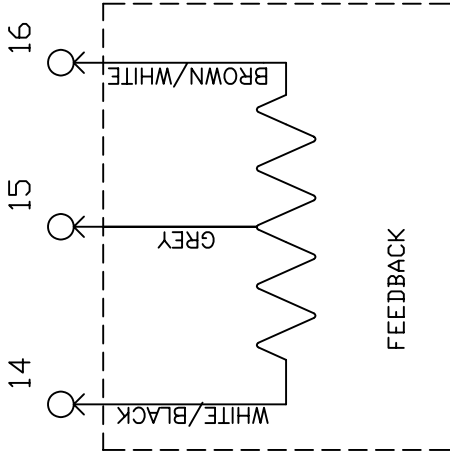

NOTES:

1. TORQUE TERMINAL STRIP WIRING TO 5 IN-LBS.
2. CONTROL WIRING SHALL BE INSULATED WITH CONDUCTORS RATED 105°C, 300V MINIMUM.
3. 75°C COPPER SUPPLY WIRES ONLY.

ASAHI/AMERICA

ISO 9001 CERTIFIED
35 GREEN STREET, P.O. BOX 653, MALDEN, MA.



QUATER MASTER - 94
OPTIONS WIRING DIAGRAM

THIS DRAWING AND ALL INFORMATION HEREON IS THE PROPERTY OF ASAHI/AMERICA. ANY COPYING, REPRODUCTION OR UNAUTHORIZED USE IS FORBIDDEN WITHOUT WRITTEN CONSENT.

NAME	DATE
DR JOHN GLASSFORD	6/18/07
APPD DAVE HURLEY	6/18/07
PROD LEO LESTER	6/19/07
WO#/SO#	
FILE	ACAD11/S92

SIZE A DWG. NO. 297S92 REV C

SCALE NTS SHEET 1 OF 1

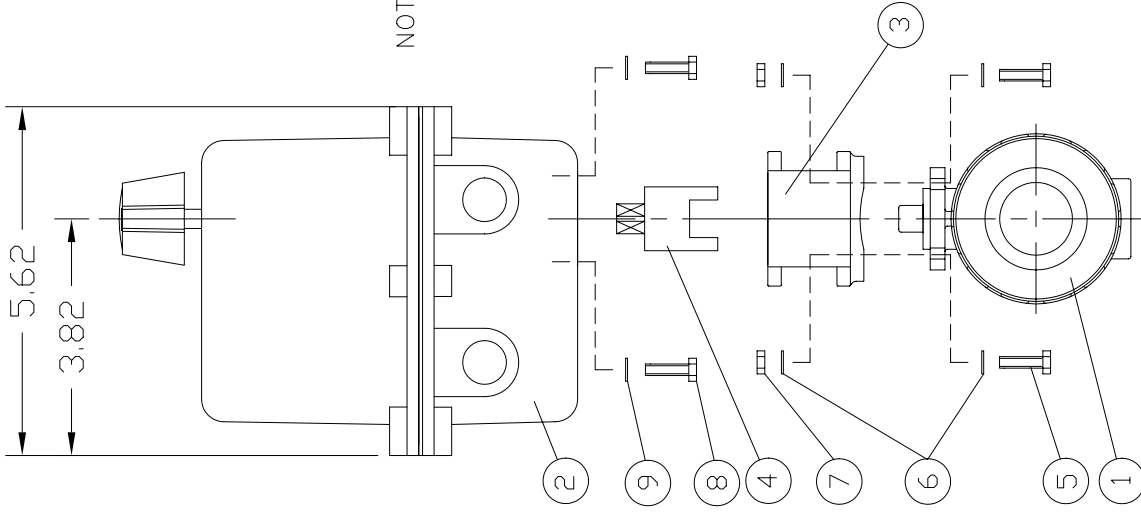

UNIT: INCH

VALVE SIZE	1/2"	3/4"	1"	1-1/4"	1-1/2"	2"
H	2.76	3.01	3.29	3.64	3.98	4.43
H1	1.14	1.38	1.54	1.85	2.17	2.60

NOTE: The shape and appearance of assembly differ a little with nominal size compared to this drawing.

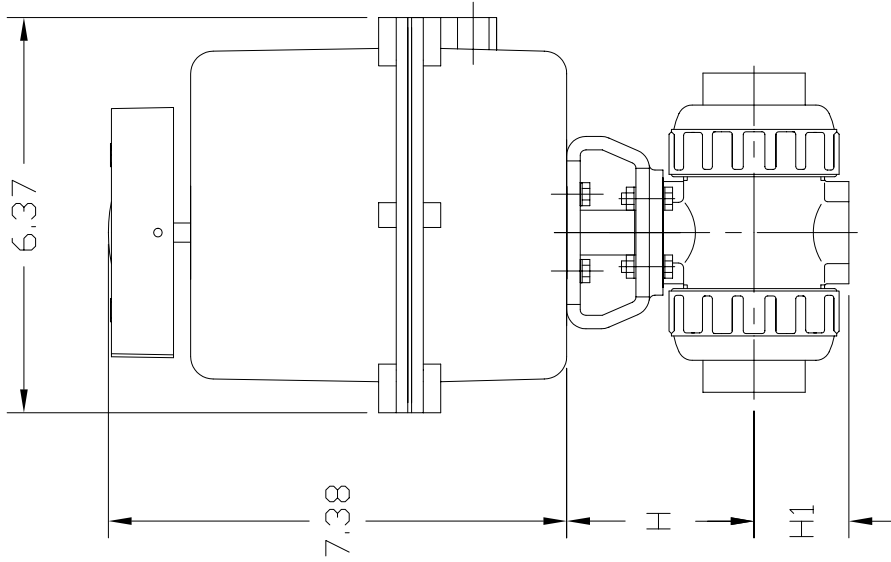

9	FLAT WASHER (M6.0)	STAINLESS STEEL	4
8	BOLT (M6.0x1-16LG)	STAINLESS STEEL	4
7	NUT (FOR 1/2" THRU 1-1/4" : M5.0x8) (FOR 1-1/2" THRU 2" : M6.0x1)	STAINLESS STEEL	4
6	FLAT WASHER (FOR 1/2" THRU 1-1/4" : M5.0) (FOR 1-1/2" THRU 2" : M6.0)	STAINLESS STEEL	8
5	BOLT (FOR 1/2" THRU 1-1/4" : M5.0x8-16LG) (FOR 1-1/2" THRU 2" : M6.0x1-20LG)	STAINLESS STEEL	4
4	COUPLING	STAINLESS STEEL 303	1
3	MOUNTING BRACKET	PPG	1
2	ACTUATOR SERIES 94	ZYTEL	1
1	BALL VALVE TYPE 21	PVC,CPVC,PP,PVDF	1
ITEM	DESCRIPTION	MATERIAL	QTY

THIS DRAWING AND ALL INFORMATION HEREON IS THE PROPERTY OF ASAHI/AMERICA. ANY COPYING, REPRODUCTION OR UNAUTHORIZED USE IS FORBIDDEN WITHOUT WRITTEN CONSENT.

NAME	DATE
DR KENICHI MIYAZAKI	8/2/01
APPD DAVE HURLEY	8/2/01
PROD LED LESTER	8/2/01
WO#/CO#	
FILE	

ASAHI/AMERICA
 ISO 9001 CERTIFIED
 35 GREEN STREET, P.O. BOX 653, MALDEN, MA.



BALL VALVE TYPE21
 SERIES94 ELECTRIC ACTUATOR
 1/2" THRU 2"

SIZE	A	DWG. NO.	0106BV	REV	A
SCALE	NTS	SHEET	1	OF	1

FOR REFERENCE ONLY
ASAHI/AMERICA

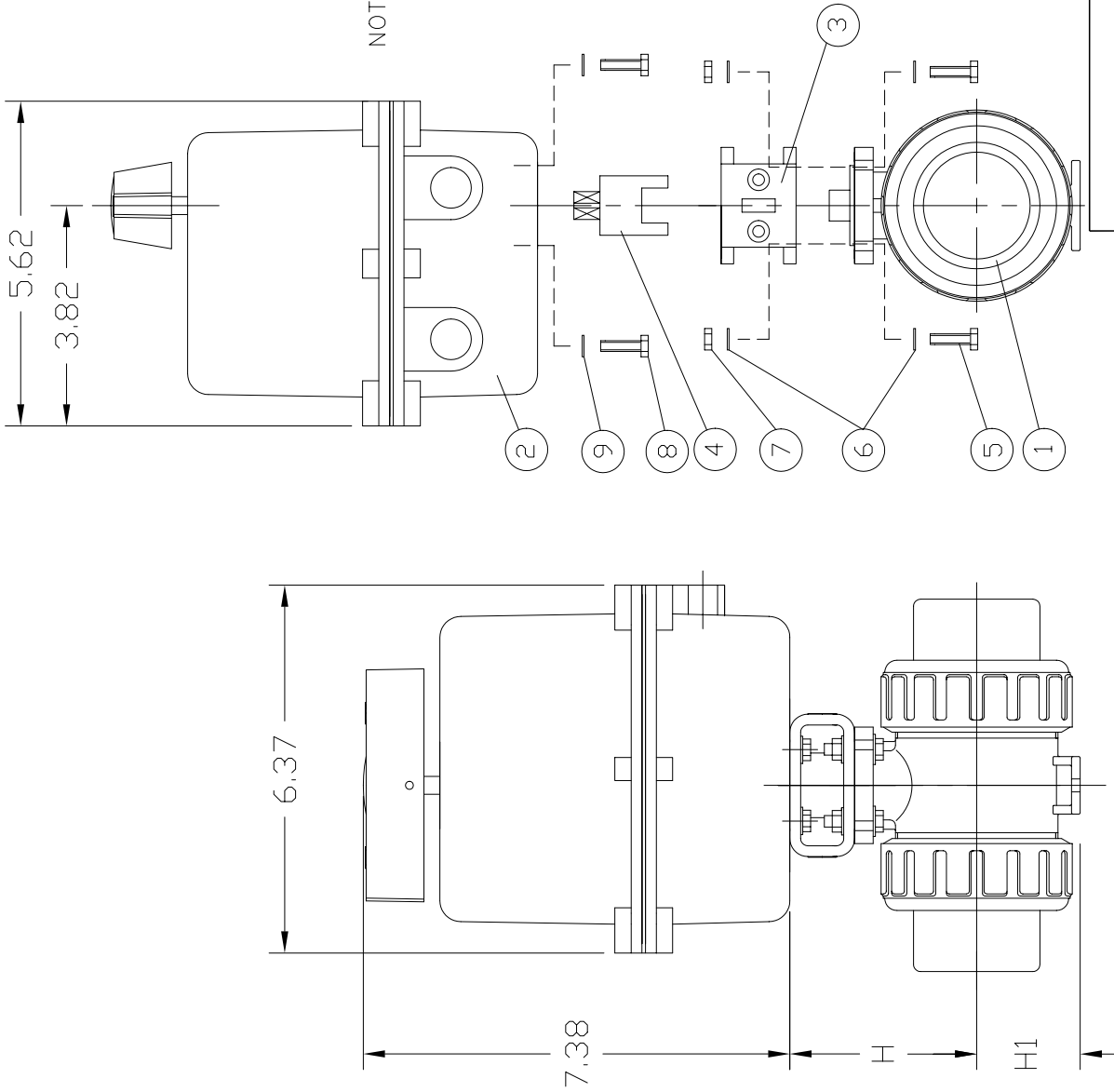

UNIT: INCH

VALVE SIZE	2-1/2"	3"
H	5.12	5.47
H1	2.83	3.35

NOTE: The shape and appearance of assembly differ a little with nominal size compared to this drawing.

ITEM	DESCRIPTION	MATERIAL	QTY
9	FLAT WASHER (M6.0)	STAINLESS STEEL	4
8	BOLT (M6.0x1-16LG)	STAINLESS STEEL	4
7	NUT (M8.0x1.25)	STAINLESS STEEL	4
6	FLAT WASHER (M8.0)	STAINLESS STEEL	8
5	BOLT (M8.0x1.25-35LG)	STAINLESS STEEL	4
4	COUPLING	STAINLESS STEEL 303	1
3	MOUNTING BRACKET	PPG	1
2	ACTUATOR SERIES 94	ZYTEL	1
1	BALL VALVE TYPE 21	PVC,CPVC,PP,PVDF	1

ASAHI/AMERICA

ISO 9001 CERTIFIED

35 GREEN STREET, P.O. BOX 653, MALDEN, MA.



BALL VALVE TYPE21
 SERIES94 ELECTRIC ACTUATOR
 2-1/2" THRU 3"

SIZE A DWG. NO. 0112BV REV A

SCALE NTS SHEET 1 OF 1

THIS DRAWING AND ALL INFORMATION HEREON IS THE PROPERTY OF ASAHI/AMERICA. ANY COPYING, REPRODUCTION OR UNAUTHORIZED USE IS FORBIDDEN WITHOUT WRITTEN CONSENT.

NAME	DATE
DR KENICHI MIYAZAKI	8/14/01
APPD DAVE HURLEY	8/14/01
PROD LEO LESTER	8/14/01
WO#/CO#	
FILE	

FOR REFERENCE ONLY
ASAHI/AMERICA

DIMENSIONS TABLE

UNIT: inch

NOMINAL SIZE	FLANGED			THREADED			PVC, CPVC			PP, PVDF (DIN)			PP, PVDF (IPS)			SOCKET		
	H	H1	L	H1	L	L	H1	L	H1	L	H1	L	H1	L	H1	L	H1	L
1/2" 15mm	2.76	3.70	5.63	2.89	4.02	3.08	4.45	2.80	3.90	3.09	4.45	3.27	4.88					
3/4	3.01	4.50	6.77	3.48	4.72	3.56	5.08	3.27	4.49	3.61	5.08	3.90	5.67					
1	3.29	5.24	7.36	4.13	5.16	4.32	5.75	3.94	4.84	4.37	5.75	4.53	6.06					
1 1/2	4.0	6.50	8.35	5.53	6.42	5.71	7.24	5.16	5.83	5.85	7.24	6.02	6.85					
2	5.0	8.0	10.0	6.61	7.76	6.66	8.23	6.06	6.93	6.76	8.23	7.01	8.82					
3	6.0	9.0	11.0	7.76	8.91	7.76	9.33	7.01	7.88	7.71	9.18	8.06	9.85					
4	7.0	10.0	12.0	8.91	10.06	8.91	10.38	7.71	8.58	8.41	9.88	8.76	10.55					

NOTE: 1) THE SHAPE AND APPEARANCE OF ASSEMBLY DIFFER A LITTLE WITH NOMINAL SIZE COMPARED TO THIS DRAWING.

2) FOR DETAILED VALVE DIMENSIONS, REFER TO DWG. NO. 0126BV, 0127BV, 0128BV. L-PORT : DWG. NO. 0126BV DOUBLE L-PORT : DWG. NO. 0127BV CROSS PORT : DWG. NO. 0128BV

FOR REFERENCE ONLY
ASAHI/AMERICA

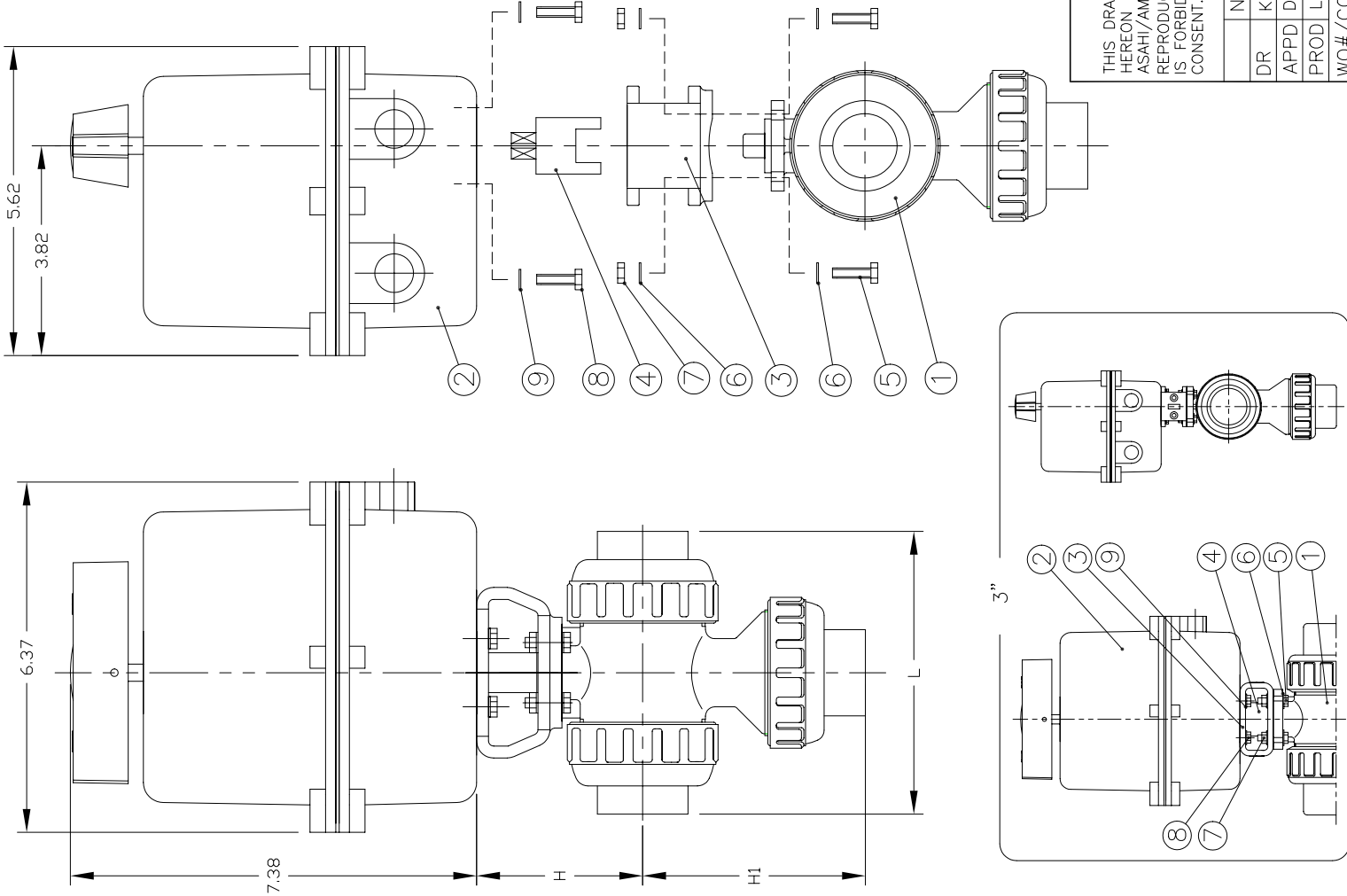

ITEM	DESCRIPTION	MATERIAL	QTY
9	FLAT WASHER (M6.0)	STAINLESS STEEL	4
8	BOLT (M6.0x1-16LG)	STAINLESS STEEL	4
7	NUT (FOR 1/2" THRU 1" : M5.0x.8) (FOR 1-1/2" THRU 2" : M6.0x1) (FOR 3" : M8.0x1.25)	STAINLESS STEEL	4
6	FLAT WASHER (FOR 1/2" THRU 1" : M5.0) (FOR 1-1/2" THRU 2" : M6.0) (FOR 3" : M8.0)	STAINLESS STEEL	8
5	BOLT (FOR 1/2" THRU 1" : M5.0x.8-16LG) (FOR 1-1/2" THRU 2" : M6.0x1-20LG) (FOR 3" : M8.0x1.25-35LG)	STAINLESS STEEL	4
4	COUPLING	STAINLESS STEEL 303	1
3	MOUNTING BRACKET	PPG	1
2	ACTUATOR SERIES 94	ZYTEL	1
1	MULTI-PORT BALL VALVE TYPE23	PVC,CPVC,PP,PVDF	1
	DESCRIPTION	MATERIAL	QTY

THIS DRAWING AND ALL INFORMATION HEREON IS THE PROPERTY OF ASAHI/AMERICA. ANY COPYING, REPRODUCTION OR UNAUTHORIZED USE IS FORBIDDEN WITHOUT WRITTEN CONSENT.

NAME	DATE
DR KENICHI MIYAZAKI	1/28/03
APPD DAVE HURLEY	1/28/03
PROD LEO LESTER	1/28/03
WO#/CO#	
FILE	

ASAHI/AMERICA

ISO 9001 CERTIFIED

35 GREEN STREET, P.O. BOX 653, MALDEN, MA.



MULTI PORT BALL VALVE
TYPE23 WITH SERIES94 ACT.
1/2" THRU 3"

SIZE	DWG. NO.	REV
A	0129BV	A

SCALE NTS

SHEET 1 OF 1

UNIT: INCH

VALVE SIZE	1-1/2"	2"	2-1/2"	3"	4"
H	5.51	5.75	6.18	6.46	7.16
H1	2.95	3.27	3.66	3.94	4.53

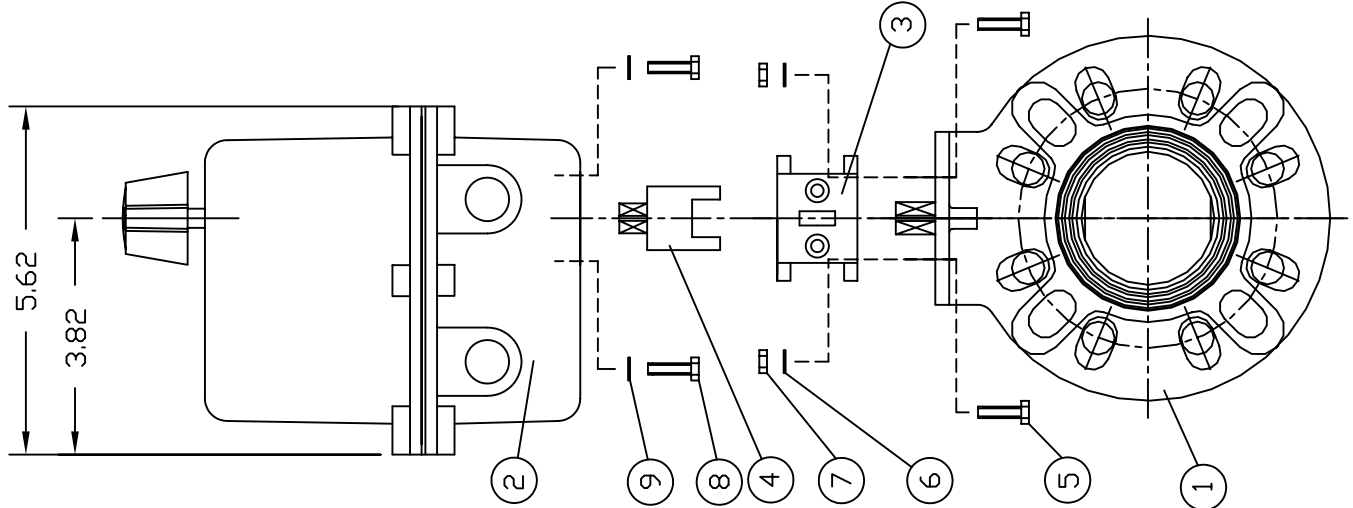
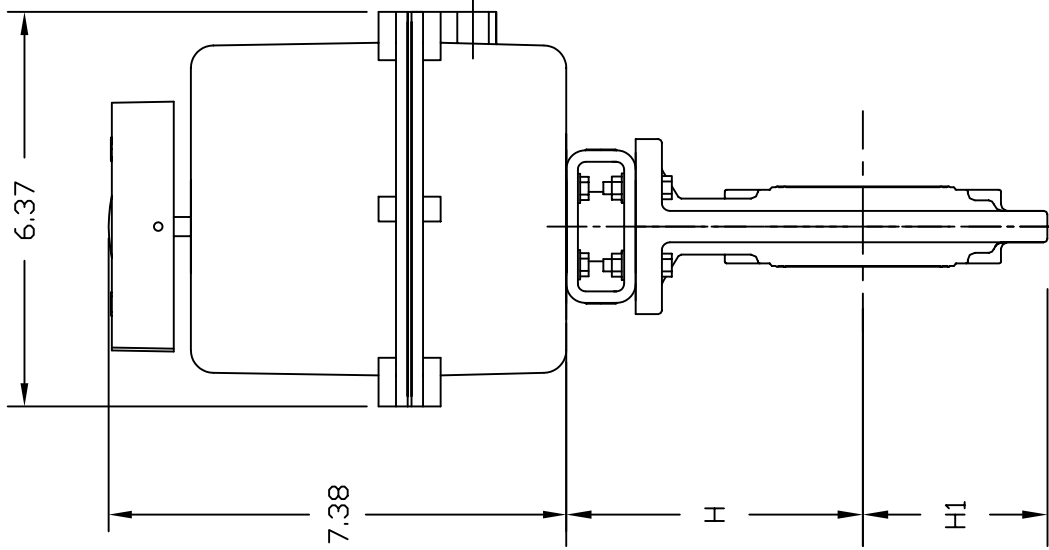

NOTE: 1. The shape and appearance of assembly differ a little with nominal size compared to this drawing.
 2. For Mounting Bracket : F07XF05, F07

FOR REFERENCE ONLY
ASAHI/AMERICA

ITEM	DESCRIPTION	MATERIAL	QTY
9	FLAT WASHER (M6.0)	STAINLESS STEEL	4
8	BOLT (M6.0x1-16LG)	STAINLESS STEEL	4
7	NUT (FOR 1-1/2" THRU. 4" : M8.0x1.25)	STAINLESS STEEL	4
6	FLAT WASHER (FOR 1-1/2" THRU. 4" : M8.0)	STAINLESS STEEL	8
5	BOLT (FOR 1-1/2" THRU. 4" : M8.0x1.25-35L0)	STAINLESS STEEL	4
4	COUPLING	STAINLESS STEEL 303	1
3	MOUNTING BRACKET	PPG	1
2	ACTUATOR SERIES 94	ZYTEL	1
1	BUTTERFLY VALVE TYPE 57	U-PVC,PP,PVDF	1

ASAHI/AMERICA

ISO 9001 CERTIFIED
 35 GREEN STREET, P.O. BOX 653, MALDEN, MA.



BUTTERFLY VALVE TYPE57
 SERIES94 ELECTRIC ACTUATOR
 1-1/2" THRU 4"

THIS DRAWING AND ALL INFORMATION HEREON IS THE PROPERTY OF ASAHI/AMERICA. ANY COPYING, REPRODUCTION OR UNAUTHORIZED USE IS FORBIDDEN WITHOUT WRITTEN CONSENT.

NAME	DATE
DR JOHN GLASSFORD	6/10/05
APPD DAVE HURLEY	6/10/05
PROD LEO LESTER	6/10/05
WO#/CO#	
FILE	

SIZE	A	DWG. NO.	0203BF57	REV	A
SCALE	NTS	SHEET	1	OF	1

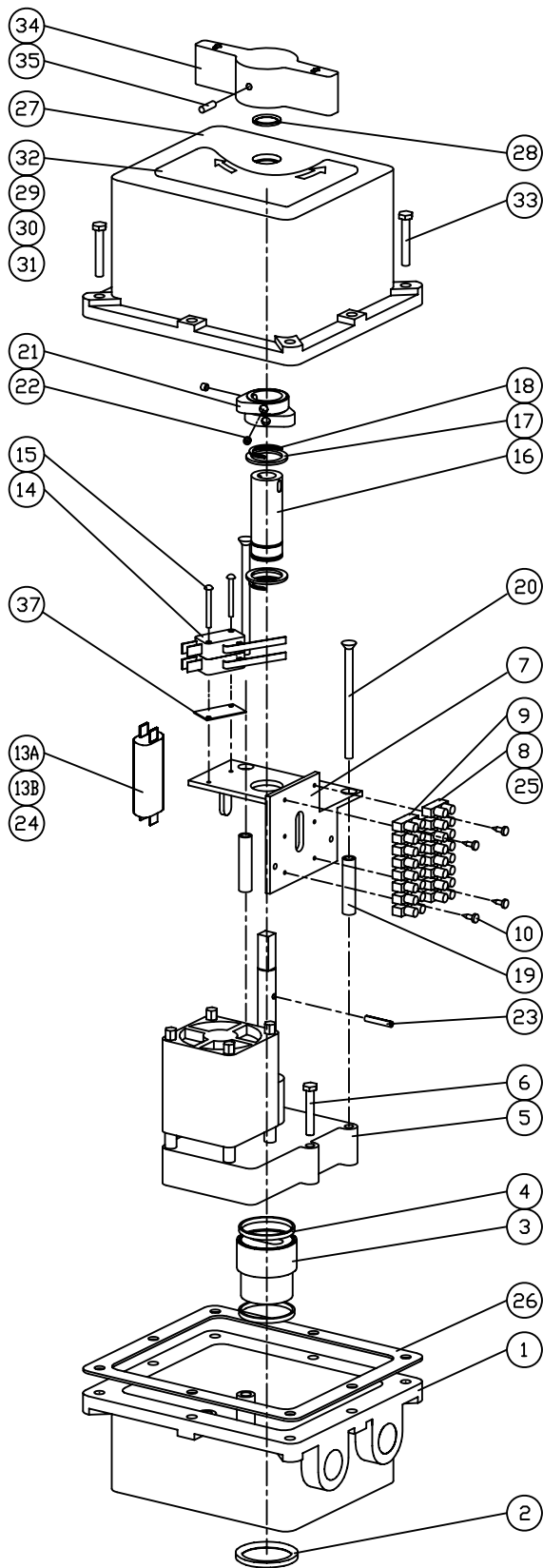

ITEM	PART NO	QTY	DESCRIPTION
1	7403002	1	BASE
2	7403000	1	BASE SEAL
3	7403017	1	OUTPUT COUPLING
4	7403005	2	COUPLING GASKET
5	7403004	1	MOTOR
6	ACTMSC	2	MOTOR SCREW
7	7403011	1	BASE PLATE
8	7401420	1	TERMINAL BLOCK 1-8
9	7401425	1	TERMINAL BLOCK 9-16
10	ACTMSC	4	TERMINAL BLOCK SCREW
13A	7401948	1	4.2 MFD CAPACITOR - A94
13B	7402004	1	6.7 MFD CAPACITOR - B94
14	7401460	2	MICRO SWITCH (V7-6C13D8-132)
15	ACTMSC	2	LIMIT SWITCH SCREW
16	7403016	1	OUTER SHAFT
17	7403006	2	OUTER SHAFT GASKET
18	ACTMSC	2	RETAINING RING
19	ACTMSC	2	STANDOFF
20	ACTMSC	2	BASE PLATE SCREW
21	7401480	2	CAM
22	ACTMSC	4	CAM SCREW
23	ACTMSC	1	PIN
24	7403023	1	2 PC HARNESS
25	7403015	1	4 PC HARNESS
26	7403007	1	BASE GASKET
27	7403001	1	COVER
28	7403020	1	COVER SEAL
29	7403019	1	WIRE DIAGRAM LABEL
30	7403025	1	OPTION LABEL
31	7403030	1	QM II LABEL
32	7403040	1	OVERRIDE LABEL
33	ACTMSC	8	COVER SCREW
34	7403003	1	HANDLE
35	ACTMSC	1	HANDLE SCREW
36	7403021	1	QM II BOX
37	7403240	1	NOMEX INSULATOR PLATE (220VAC ONLY)

NOTE:

1. LOCATE ITEM 29 & 30 ON INSIDE SURFACES OF COVER (ITEM 27).
2. LOCATE ITEM 31 ON OUTSIDE BACK SURFACE OF COVER (ITEM 27).

THIS DRAWING AND ALL INFORMATION HEREON IS THE PROPERTY OF ASAHI/AMERICA. ANY COPYING, REPRODUCTION OR UNAUTHORIZED USE IS FORBIDDEN WITHOUT WRITTEN CONSENT.

	NAME	DATE
DR	J.GLASSFORD	6/18/07
APPD	D.HURLEY	6/18/07
PROD	L.LESTER	6/19/07
WO#/SO#		
FILE	ACAD11/QM	

ASAHI/AMERICA

ISO 9001 CERTIFIED

35 GREEN STREET, P.O. BOX 653, MALDEN, MA.



SERIES 94
EXPLODED VIEW

SIZE	A	DWG. NO.	279QM	REV	D
SCALE	NTS		SHEET 1 OF 1		

REV	DATE	DESCRIPTION	BY	FROM
A	6/22/17	FIRST ISSUE	JH	KB

AC WIRING DIAGRAM

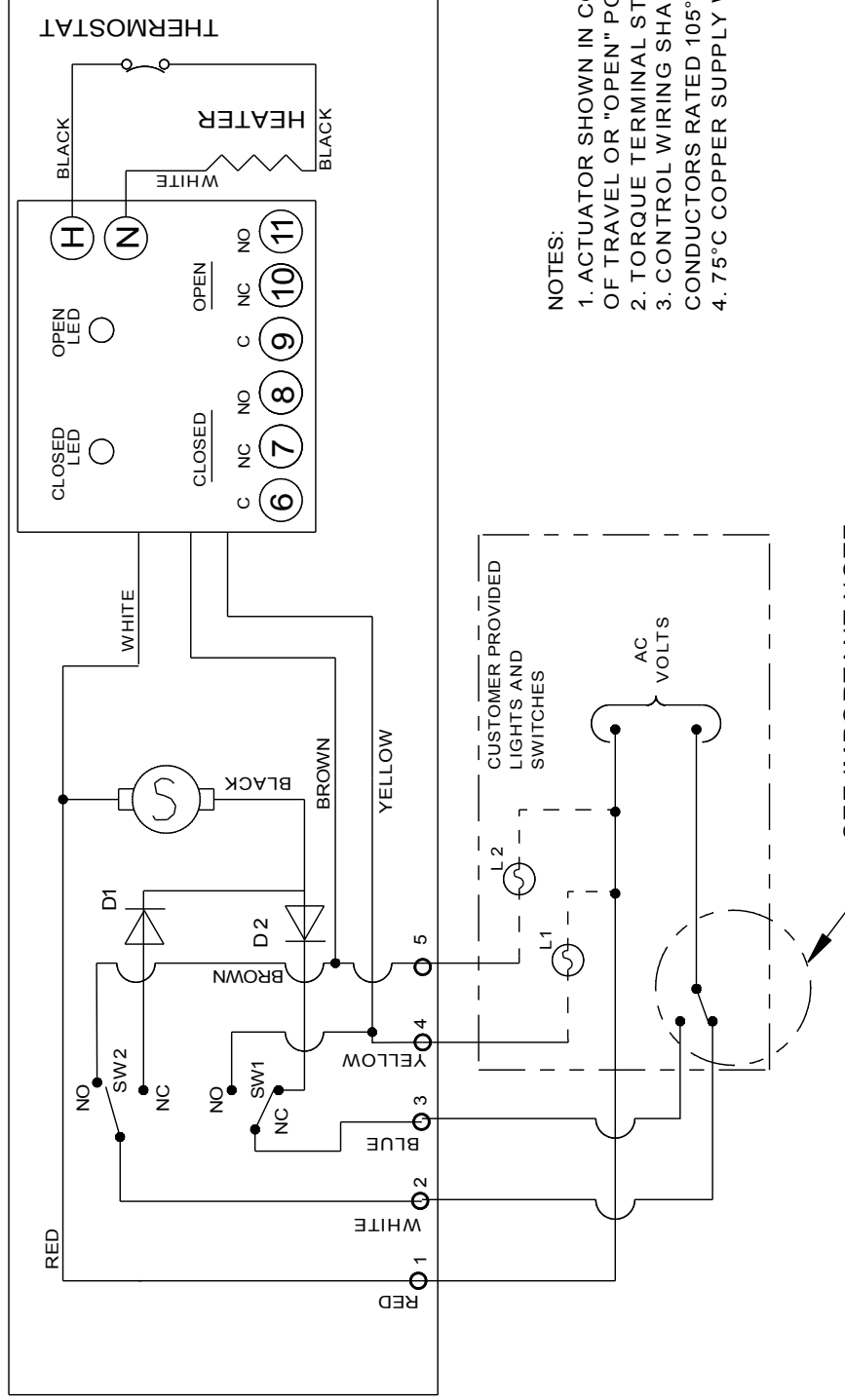

NOTES:

1. ACTUATOR SHOWN IN COUNTER CLOCKWISE EXTREME OF TRAVEL OR "OPEN" POSITION.
2. TORQUE TERMINAL STRIP WIRING TO 5 IN.-LBS.
3. CONTROL WIRING SHALL BE INSULATED WITH CONDUCTORS RATED 105°C, 300V MINIMUM.
4. 75°C COPPER SUPPLY WIRES ONLY.

SEE IMPORTANT NOTE

UNLESS OTHERWISE SPECIFIED	
DIMENSIONS ARE IN INCHES	
MACHINING	2 PL DECIMALS ± 01
TOLERANCES:	3 PL DECIMALS ± 005
	ANGULAR ± 1/2°
	FRACTIONAL ± 1/64
FABRICATION	1/2" - 8" ± 1/4
TOLERANCES:	10" AND UP ± 1/2
	ANGULAR ± 1.0°
WELD TYPE:	N/A
MATERIAL:	AS NOTED
FINISH:	125μ"

THIS DRAWING AND ALL INFORMATION HEREIN IS THE PROPERTY OF ASAHI/AMERICA. ANY COPYING, REPRODUCTION OR UNAUTHORIZED USE IS FORBIDDEN WITHOUT WRITTEN CONSENT.	
DR	J. Hughes
REV	
APPR	K. Blystone
PRODUCT:	VALVE & ACT
WO#/SO#	

ASAHI/AMERICA
ISO 9001 CERTIFIED
 655 ANDOVER STREET, LAWRENCE, MA

SERIES 94 WITH RHM WIRING
DIAGRAM 12/24 VAC

JDE PART # M00EL9903

SIZE	A	DWG #	M00EL9903	REVISION	A
SCALE	N/A	SHEET	1	OF	1

REV	DATE	DESCRIPTION	BY	FROM
A	6/22/17	FIRST ISSUE	JH	KB

DC WIRING DIAGRAM

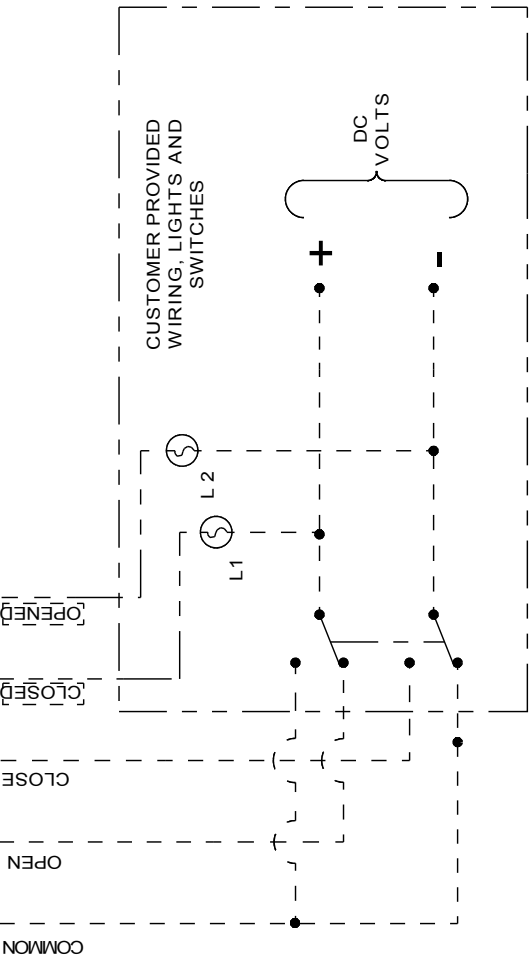
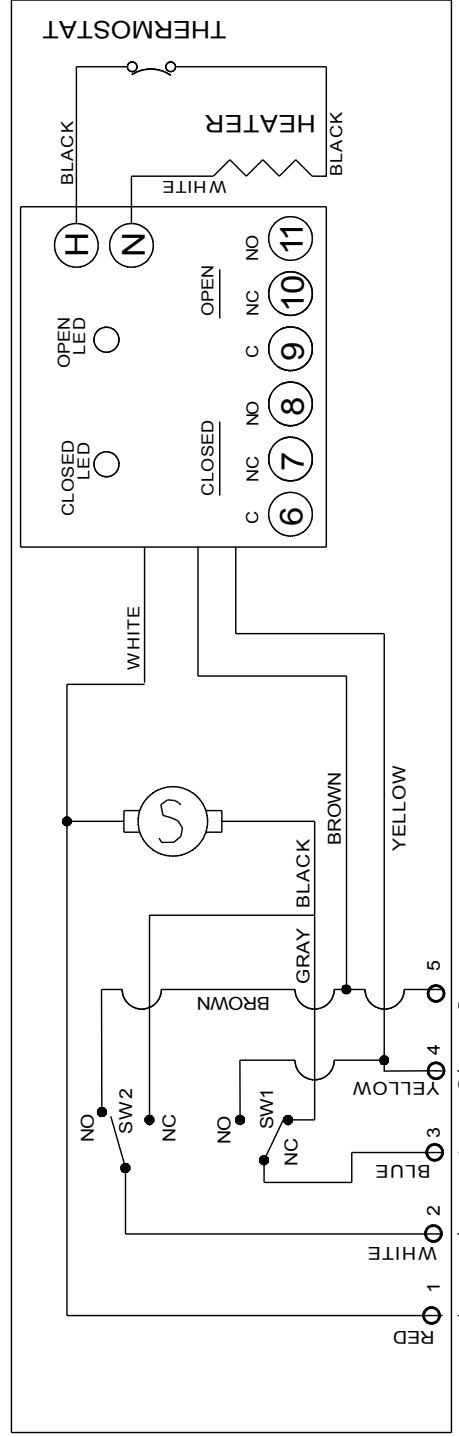

NOTES:

1. ACTUATOR SHOWN IN COUNTER CLOCKWISE EXTREME OF TRAVEL OR "OPEN" POSITION.
2. TORQUE TERMINAL STRIP WIRING TO 5 IN-LBS.
3. CONTROL WIRING SHALL BE INSULATED WITH CONDUCTORS RATED 105°C, 300V MINIMUM.
4. 75°C COPPER SUPPLY WIRES ONLY.

UNLESS OTHERWISE SPECIFIED

DIMENSIONS ARE IN INCHES	
MACHINING	2 PL DECIMALS ± .01
TOLERANCES:	3 PL DECIMALS ± .005
ANGULAR	± 1/2°
FRACTIONAL	± 1/64
1/2" - 8"	± 1/4
10" AND UP	± 1/2
ANGULAR	± 1.0°
WELD TYPE:	N/A
MATERIAL:	AS NOTED
FINISH:	125μ"

THIS DRAWING AND ALL INFORMATION HEREIN IS THE PROPERTY OF ASAHII/AMERICA. ANY COPYING, REPRODUCTION OR UNAUTHORIZED USE IS FORBIDDEN WITHOUT WRITTEN CONSENT.	
DR	J. Hughes
REV	
APPR	K. Blystone
DATE	06/22/17
PRODUCT:	VALVE & ACT
WO#/SO#	

ASAHI/AMERICA
ISO 9001 CERTIFIED
 655 ANDOVER STREET, LAWRENCE, MA

SERIES 94 WITH RHM WIRING
DIAGRAM 12/24 VDC

JDE PART # M00EL9904

SIZE	A	DWG #	M00EL9904	REVISION	A
SCALE	N/A	SHEET	1	OF	1

REV	DATE	DESCRIPTION	BY	FROM
A	6/22/17	FIRST ISSUE	JH	KB

WIRING DIAGRAM FOR 120 VAC AND 220 VAC ONLY
ACTUATOR SHOWN IN COUNTER-CLOCKWISE EXTREME OF TRAVEL, OR "OPEN" POSITION

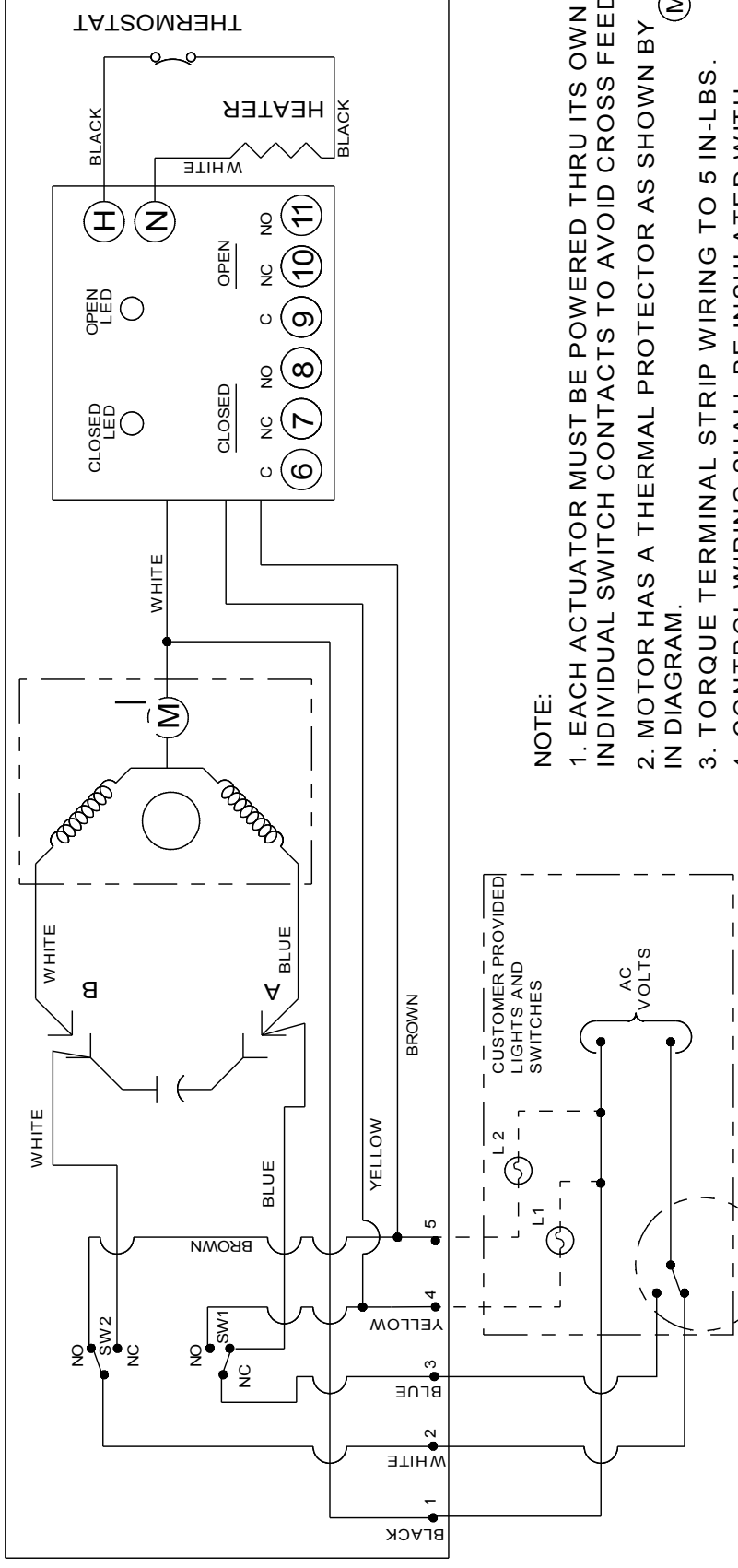

NOTE:

1. EACH ACTUATOR MUST BE POWERED THRU ITS OWN INDIVIDUAL SWITCH CONTACTS TO AVOID CROSS FEED.
2. MOTOR HAS A THERMAL PROTECTOR AS SHOWN BY (M) IN DIAGRAM.
3. TORQUE TERMINAL STRIP WIRING TO 5 IN-LBS.
4. CONTROL WIRING SHALL BE INSULATED WITH CONDUCTORS RATED 105°C, 300V MINIMUM.
5. 75°C COPPER SUPPLY WIRES ONLY.

SEE IMPORTANT NOTE

UNLESS OTHERWISE SPECIFIED	
DIMENSIONS ARE IN INCHES	
MACHINING	2 PL DECIMALS ± .01
TOLERANCES:	3 PL DECIMALS ± .005
ANGULAR	± 1/2°
FRACTIONAL	± 1/64
FABRICATION	± 1/4
TOLERANCES:	10" AND UP ± 1/2
ANGULAR	± 1.0°
WELD TYPE:	N/A
MATERIAL:	AS NOTED
FINISH:	125μ"

THIS DRAWING AND ALL INFORMATION HEREIN IS THE PROPERTY OF ASAHI/AMERICA. ANY COPYING, REPRODUCTION OR UNAUTHORIZED USE IS FORBIDDEN WITHOUT WRITTEN CONSENT.			
DR	NAME	DATE	
REV	J. Hughes	06/22/17	
APPR	K. Blystone	06/22/17	
PRODUCT:	VALVE & ACT		
WO#/SO#			

ASAHI/AMERICA
ISO 9001 CERTIFIED
655 ANDOVER STREET, LAWRENCE, MA

SERIES 94 WITH RHM WIRING
DIAGRAM 120/220 VAC

JDE PART # M00EL9905

SIZE	A	DWG #	M00EL9905	REVISION	A
SCALE	N/A	SHEET	1	OF	1