

FALCONICS™

Flow Controller for CMP Slurry

- Fast and accurate flow control reduces waste
- Ultrasonic Technology generates precision
- Straight flow path prevents slurry clogging
- Dymatrix™ Pinch Valve provides long life



Falconics™ Technology

Asahi's patented Ultrasonic Flow Meter Technology and Dymatrix™ Pinch Valves make Falconics™ the ultimate choice for flow control of CMP slurry. Our Ultrasonic Technology creates a directionally concentrated and repeatable flow signal despite bubbles and temperature fluctuations. Asahi's proven Dymatrix™ Pinch Valve offers the most durable and reliable valve for aggressive slurry. Together these features provide highly accurate control and fast response times, which generates a strong ROI.

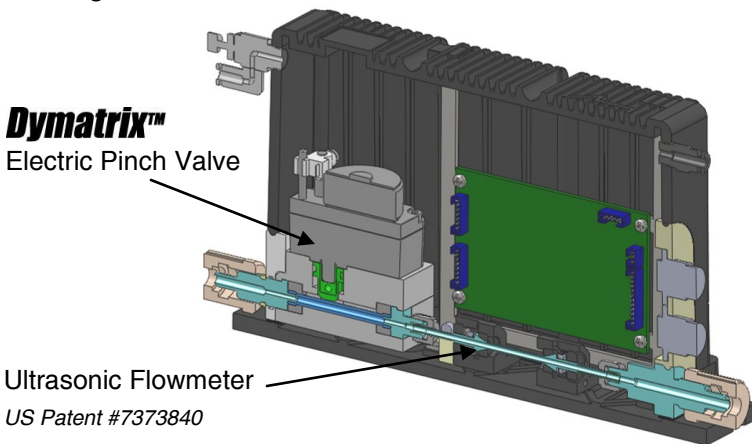

Specifications

Flow Ranges	50 - 500 mL/min 25 - 250 mL/min
Accuracy	3% S.P. (1% S.P. Typ. Act.) +/- 3mL/min @ ≤ 100mL/min
Repeatability	1.5% S.P. +/- 1.5mL/min @ ≤ 100mL/min
Response time	< 3.0 sec (1 sec Typ. Act.)
Shut off speed	< 3.0 sec
Operating Pressure	14.5 – 43.5 psi
Flush Pressure*	80 psi
Medium Temp.	59 – 95 F (15 - 35 C)
End Connection	1/4" Flare or S300
Voltage	24 V DC
Current Draw	0.4 A
Output Signals	4-20mA, 0-5V, 0-10V
Signal Connection	RS 485
Purge Flow Rate	20 L/min (ANR)
Purge Connector	5/32" OD

*Unit should not be operating to set point during flush mode.

Flow Characteristics

- Falconics™ responds and stabilizes much faster than competitive flow controllers
- No overshoot eliminates slurry waste
- Please contact us to discuss all our exciting performance data

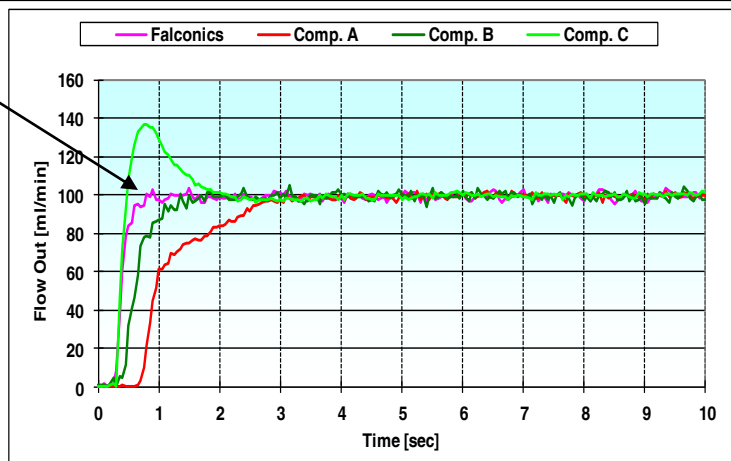

Dimensions

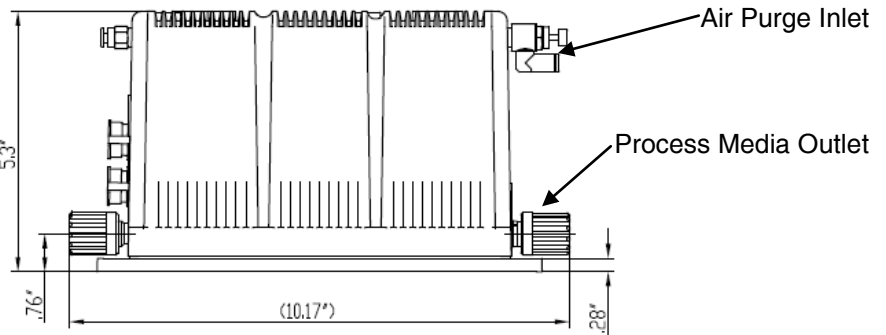
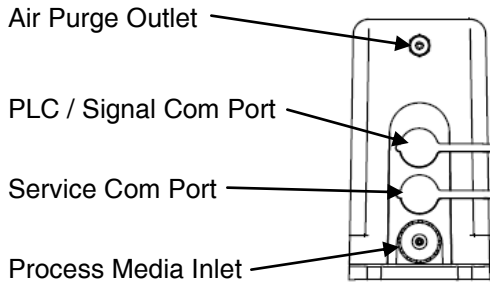
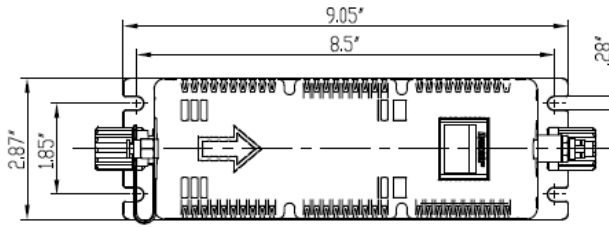

Ordering Info

The following models have 1/4" Flare connections. Additional configurations are available.

Flow Range	Temperature Control	Part #
25 - 250 mL/min	Yes	6179001
50 - 500 mL/min	Yes	6179002
25 - 250 mL/min	No	6179003
50 - 500 mL/min	No	6179004

Calibration Kit

It is recommended that customers order at least one Calibration Kit (sold separately). The kit includes the Falconics™ Calibration Software, RS485 to USB converter and extension communication cable. This kit allows the customer to connect to the "Service Com Port" for calibration and troubleshooting from their computer.

Falconics™ Calibration Kit #6179100

Falconics™ Calibration Software

The Falconics™ Calibration Software is a user friendly interface to configure the flow controller to the customer's specific media properties. It provides in depth diagnostics of flow alarms and troubleshooting of control issues. This software is included in the optional Calibration Kit.

