

MEASUREMENT AND  
CONTROL TECHNOLOGY.

FLOW METER.



**The  
Wet  
Process  
People™**

Asahi/America, Inc.  
35 Green Street  
Malden, MA 02148  
Phone: (800) 343-3618  
[www.asahi-america.com](http://www.asahi-america.com)



## Float-type flow meter

DN	Inches	da	Measuring range H <sub>2</sub> O	M 335 / M 350	M 123	M 10-13
10	3/8	16	1.5-15		■ ●	◆
10	3/8	16	2.5-25		■ ●	◆
10	3/8	16	5-50		■ ●	◆
10	3/8	16	10-100		■ ●	◆
15	1/2	20	8-80		■ ●	
15	1/2	20	15-150		■ ●	
15	1/2	20	20-200		■ ●	
25	1	32	15-150		■ ●	
25	1	32	30-300		■ ●	
25	1	32	50-500	▲ ■ ●	■ ●	
25	1	32	100-1,000	▲ ■ ●	■ ●	
32	1 1/4	40	150-1,500	▲ ■ ●		
32	1 1/4	40	250-2,500	▲ ■ ●		
40	1 1/2	50	200-2,000	▲ ■ ●		
40	1 1/2	50	300-3,000	▲ ■ ●		
40	1 1/2	50	600-6,000	▲ ■ ●		
50	2	63	600-6,000	▲ ■ ●		
50	2	63	1,200-12,000	▲ ■ ●		
50	2	63	1,500-15,000	▲ ■ ●		
65	2 1/2	75	2,000-20,000	▲ ■ ●		
65	2 1/2	75	3,000-30,000	▲ ■ ●		
65	2 1/2	75	8,000-60,000	▲ ■ ●		

	Connection type	Sealing elements	Float	Connection
Standard	PVC adhesive socket	EPDM	PVDF	M 10-13 R 1/4" female thread
on request	PP-/PE-/PVDF fusion socket PP-/PE-/PVDF butt fusion spigot Va/Tg female thread	FPM (Viton)	Va 1.4571 (M 10-13)	M 11+13 also R 5/8" male thread

### Key to symbols

- ▲ PA (polyamide Trogamid)
- PSU (polysulphone)
- PVC
- ◆ PMMA (polymethylmethacrylate "Plexiglas")

Va 1.4571

Tg Malleable cast iron

## Flow meter M 335 / M 350

Measuring ranges 50–60,000 l/h



### Function

The FRANK flow meter M 335/M 350 operates on the float principle and is used for flow rate measurements in closed pipelines. The medium flows through the vertically installed flow meter from bottom to top. This raises the float and shows the current flow rate on the scale on the measuring device. The read-off edge corresponds to the largest diameter of the float.

FRANK M 335/M 350 flow meters come as standard with a water scale and a % scale, and two setpoint indicators.

### Special features:

- Fracture-proof and corrosion-resistant
- Radially removable
- Special adhesive scales for liquid and gaseous media
- Holder for accessories (limit value contacts)
- Measuring tube carries the DN label, and also the measuring range and material
- PVDF floats and stops as standard
- Measuring ranges 50–60,000 l/h

### Materials

Measuring tube	max. temp. at 1 bar	Float	Top and bottom inserts	O-ring
PA	+60 °C	PVDF (standard)	PVDF	EPDM
PVC	+40 °C			FPM (Viton)
PSU	+100 °C*			

Operating pressure: max. PN 10 at 20 °C

\*only with PVDF screw connection

### Connection possibilities

Socket	Spigot	Plastic female thread	Metal female thread
PVC adhesive socket (standard)	PP fusion spigot	PVC	Stainless steel V4A
PP fusion socket	PVDF fusion spigot	PP	Malleable cast iron
PVDF fusion socket	PE fusion spigot	PVDF	

### Pressure loss

Measuring range l/h	50–500	100–1,000	150–1,500	250–2,500	200–2,000	300–3,000
Pressure loss mbar	22.84	22.84	22.84	22.84	24.99	24.99

Measuring range l/h	600–6,000	1,000–10,000	1,500–15,000	2,000–20,000	3,000–30,000	8,000–60,000
Pressure loss mbar	24.99	24.99	28.23	45.67	45.67	47.24

### Measuring accuracy Accuracy Class 4 as defined by VDE/DIN 3513 Page 2

Flow in %	10	20	30	40	50	60	70	80	90	100
Total measured value error in %	13.00	8.00	6.33	5.50	5.00	4.67	4.43	4.25	4.11	4.00
Total limit value error in %	1.3	1.6	1.9	2.2	2.5	2.9	3.1	3.4	3.7	4.0

Individual parts

Pos.	Designation	Qty.	Material
1	Measuring tube	1	PA, PVC, PSU, PVDF
2	Float	1	PVDF
3	Insert, bottom	1	PVDF
4	Insert, top	1	PVDF
5	Union nut	2	PVC, PP, PVDF
6	Insertion part (socket, spigot)	2	PVC, PP, PVDF
7	O-ring	2	EPDM, FPM
8	Setpoint indicator	2	PS
9	Guide rod	1	PEEK*

\*from DN 50 1,500–15,000 l/h

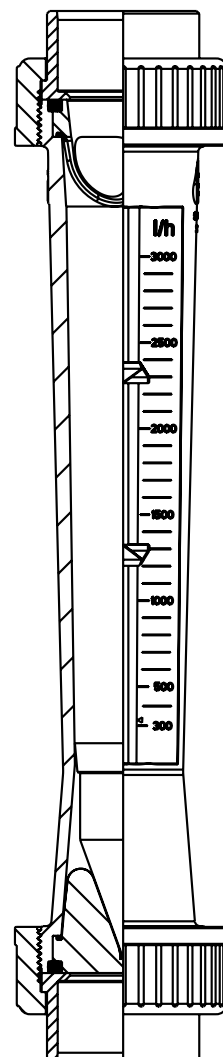
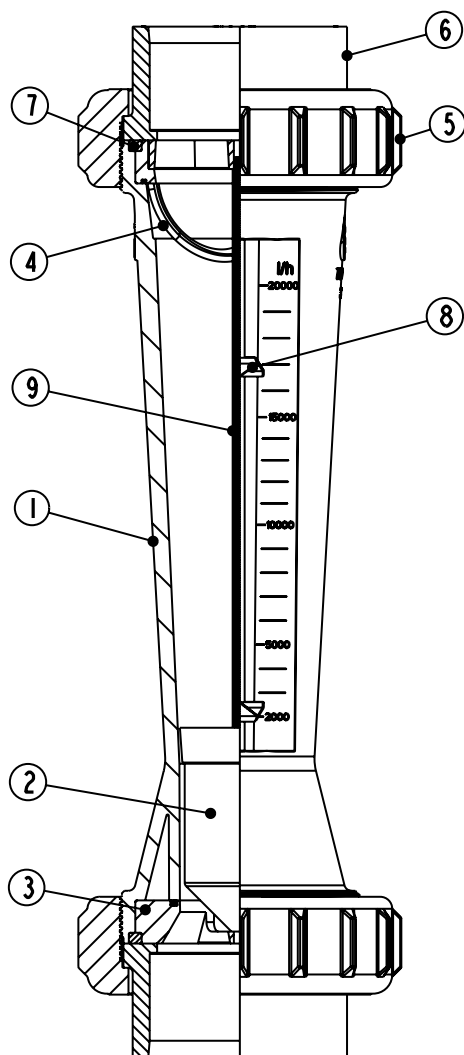

### Dimensions and weights

Type M335	Dimensions in mm																			Weight in kg/unit. approx.	
Measuring range l/h H <sub>2</sub> O						Adhesive socket			Fusion socket			Spigot PP			Spigot PVDF			Threaded socket			PA PSU PVC
	DN	d <sub>a</sub>	G	d <sub>ii</sub>	L	d <sub>m</sub>	z	L <sub>m</sub>	d <sub>m</sub>	z	L <sub>m</sub>	d	L <sub>g</sub>	S SDR 11	d	L <sub>g</sub>	S SDR 33	d <sub>g</sub>	L <sub>g</sub>	l <sub>g</sub>	
50-500 100-1,000	25	32	1 1/2"	60	335	32	341	385	32	345	381	32	455	2.9	32	443	2.4	1"	385	17	0.52
150-1,500 250-2,500	32	40	2"	72	335	40	341	393	40	345	385	40	461	3.7	40	461	2.4	1 1/4"	393	19	0.60
200-2,000 300-3,000 600-6,000	40	50	2 1/4"	83	335	50	341	403	50	345	391	50	467	4.6	50	459	3	1 1/2"	403	23	1.22
600-6,000 1,000-10,000 1,500-15,000	50	63	2 3/4"	103	335	63	341	417	63	345	399	63	473	5.8	63	461	3	2"	417	23	1.68
2,000-20,000 3,000-30,000 8,000-60,000	65	75	3 1/2"	122	335	75	341	429	75	345	407	75	587	6.9	75	453	3.6	2 1/2"	-	-	2.90

Type M350	Dimensions in mm																			Weight in kg/unit. approx.	
Measuring range l/h H <sub>2</sub> O						Adhesive socket			Fusion socket			Spigot PP			Spigot PVDF			Threaded socket			PA PSU PVC
	DN	d <sub>a</sub>	G	d <sub>ii</sub>	L	d <sub>m</sub>	z	L <sub>m</sub>	d <sub>m</sub>	z	L <sub>m</sub>	d	L <sub>g</sub>	S SDR 11	d	L <sub>g</sub>	S SDR 33	d <sub>g</sub>	L <sub>g</sub>	l <sub>g</sub>	
50-500 100-1,000	25	32	1 1/2"	60	350	32	356	400	32	360	396	32	460	2.9	32	458	2.4	1"	400	17	0.52
150-1,500 250-2,500	32	40	2"	72	350	40	356	408	40	360	400	40	476	3.7	40	476	2.4	1 1/4"	408	19	0.60
200-2,000 300-3,000 600-6,000	40	50	2 1/4"	83	350	50	356	418	50	360	406	50	482	4.6	50	474	3	1 1/2"	418	23	1.22
600-6,000 1,000-10,000 1,500-15,000	50	63	2 3/4"	103	350	63	356	432	63	360	414	63	488	5.8	63	476	3	2"	432	23	1.8
2,000-20,000 3,000-30,000 8,000-60,000	65	75	3 1/2"	122	350	75	356	444	75	360	422	75	602	6.9	75	468	3.6	2 1/2"	444	-	2.90

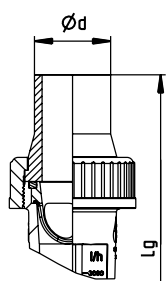

Screw connection with fusion spigot

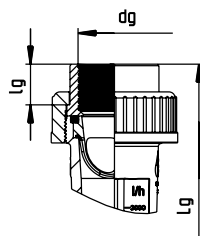

Screw connection with threaded socket

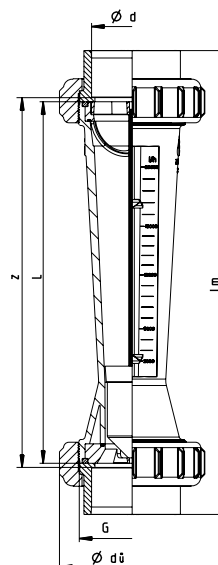

Article numbers

		Measuring tube	Type M 335		Type M 350	
da	DN		Measuring range l/h	PA	PA	PA
			Float PVDF Art. No.	Float PVDF/Solenoid Art. No.	Float PVDF Art. No.	Float PVDF/Solenoid Art. No.
32	25	50-500	17.100.214	17.100.256	17.100.298	17.100.340
32	25	100-1,000	17.100.215	17.100.257	17.100.299	17.100.341
40	32	150-1,500	17.100.216	17.100.258	17.100.300	17.100.342
40	32	250-2,500	17.100.217	17.100.259	17.100.301	17.100.343
50	40	200-2,000	17.100.218	17.100.260	17.100.302	17.100.344
50	40	300-3,000	17.100.219	17.100.261	17.100.303	17.100.345
50	40	600-6,000	17.100.220	17.100.262	17.100.304	17.100.346
63	50	600-6,000	17.100.221	17.100.263	17.100.305	17.100.347
63	50	1,000-10,000	17.100.222	17.100.264	17.100.306	17.100.348
63	50	1,500-15,000	17.100.224	17.100.266	17.100.308	17.100.350
75	65	2,000-20,000	17.100.225	17.100.267	17.100.309	17.100.351
75	65	3,000-30,000	17.100.226	17.100.268	17.100.310	17.100.352
75	65	8,000-60,000	17.100.227	17.100.269	17.100.311	17.100.353

		Measuring tube	PSU		PSU	
32	25	50-500	17.100.228	17.100.270	17.100.312	17.100.354
32	25	100-1,000	17.100.229	17.100.271	17.100.313	17.100.355
40	32	150-1,500	17.100.230	17.100.272	17.100.314	17.100.356
40	32	250-2,500	17.100.231	17.100.273	17.100.315	17.100.357
50	40	200-2,000	17.100.232	17.100.274	17.100.316	17.100.358
50	40	300-3,000	17.100.233	17.100.275	17.100.317	17.100.359
50	40	600-6,000	17.100.234	17.100.276	17.100.318	17.100.360
63	50	600-6,000	17.100.235	17.100.277	17.100.319	17.100.361
63	50	1,000-10,000	17.100.236	17.100.278	17.100.320	17.100.362
63	50	1,500-15,000	17.100.238	17.100.280	17.100.322	17.100.364
75	65	2,000-20,000	17.100.239	17.100.281	17.100.323	17.100.365
75	65	3,000-30,000	17.100.240	17.100.282	17.100.324	17.100.366
75	65	8,000-60,000	17.100.241	17.100.283	17.100.325	17.100.367

		Measuring tube	PVC		PVC	
32	25	50-500	17.100.200	17.100.242	17.100.284	17.100.326
32	25	100-1,000	17.100.201	17.100.243	17.100.285	17.100.327
40	32	150-1,500	17.100.202	17.100.244	17.100.286	17.100.328
40	32	250-2,500	17.100.203	17.100.245	17.100.287	17.100.329
50	40	200-2,000	17.100.204	17.100.246	17.100.288	17.100.330
50	40	300-3,000	17.100.205	17.100.247	17.100.289	17.100.331
50	40	600-6,000	17.100.206	17.100.248	17.100.290	17.100.332
63	50	600-6,000	17.100.207	17.100.249	17.100.291	17.100.333
63	50	1,000-10,000	17.100.208	17.100.250	17.100.292	17.100.334
63	50	1,500-15,000	17.100.210	17.100.252	17.100.294	17.100.336
75	65	2,000-20,000	17.100.211	17.100.253	17.100.295	17.100.337
75	65	3,000-30,000	17.100.212	17.100.254	17.100.296	17.100.338
75	65	8,000-60,000	17.100.213	17.100.255	17.100.297	17.100.339

### Special scales

Measuring range	Air 0 bar		Air 1 bar		Air 2 bar		Air 3 bar	
H <sub>2</sub> O l/h	Art. No.	N m <sup>3</sup> /h	Art. No.	N m <sup>3</sup> /h	Art. No.	N m <sup>3</sup> /h	Art. No.	N m <sup>3</sup> /h
50-500	00.005.526	1.5-14	00.005.602	3-20	00.005.615	3-24	00.005.628	3-28
100-1,000	00.005.527	2.5-29	00.005.603	4-41	00.005.616	5-50	00.005.629	5-58
150-1,500	00.005.528	4-45	00.005.604	6-63	00.005.617	7-77	00.005.630	8-90
250-2,500	00.005.529	7-79	00.005.605	10-111	00.005.618	12-136	00.005.631	14-158
200-2,000	00.005.530	6-58	00.005.606	9-82	00.005.619	11-100	00.005.632	12-116
300-3,000	00.005.531	9-108	00.005.607	13-152	00.005.620	16-186	00.005.633	18-216
600-6,000	00.005.532	17-174	00.005.608	24-246	00.005.621	30-301	00.005.634	34-348
600-6,000	00.005.533	17-175	00.005.609	24-247	00.005.622	30-302	00.005.635	34-350
1,000-10,000	00.005.534	29-301	00.005.610	41-425	00.005.623	51-520	00.005.636	58-602
1,500-15,000	00.005.535	53-405	00.005.611	75-572	00.005.624	92-700	00.005.637	106-810
2,000-20,000	00.005.536	55-545	00.005.612	78-770	00.005.625	96-942	00.005.638	110-1,090
3,000-30,000	00.005.537	80-758	00.005.613	113-1,072	00.005.626	139-1,311	00.005.639	160-1,516
8,000-60,000	00.005.538	-	00.005.614	-	00.005.627	-	00.005.640	-

Measuring range	Air 4 bar		Air 5 bar		Air 6 bar		Air 7 bar	
H <sub>2</sub> O l/h	Art. No.	N m <sup>3</sup> /h	Art. No.	N m <sup>3</sup> /h	Art. No.	N m <sup>3</sup> /h	Art. No.	N m <sup>3</sup> /h
50-500	00.005.641	4-31	00.005.654	4-34	00.005.667	5-37	00.005.680	5-39
100-1,000	00.005.642	6-65	00.005.655	7-71	00.005.668	7-76	00.005.681	8-82
150-1,500	00.005.643	9-100	00.005.656	10-110	00.005.669	11-119	00.005.682	12-127
250-2,500	00.005.644	16-177	00.005.657	18-193	00.005.670	19-209	00.005.683	20-223
200-2,000	00.005.645	14-130	00.005.658	15-142	00.005.671	16-153	00.005.684	17-164
300-3,000	00.005.646	21-241	00.005.659	23-264	00.005.672	24-286	00.005.685	26-305
600-6,000	00.005.647	39-389	00.005.660	42-426	00.005.673	45-461	00.005.686	49-492
600-6,000	00.005.648	39-392	00.005.661	42-428	00.005.674	45-463	00.005.687	49-495
1,000-10,000	00.005.649	65-674	00.005.662	72-737	00.005.675	77-797	00.005.688	83-851
1,500-15,000	00.005.650	119-907	00.005.663	130-992	00.005.676	141-1,073	00.005.689	150-1,146
2,000-20,000	00.005.651	124-1,220	00.005.664	135-1,335	00.005.677	146-1,444	00.005.690	156-1,542
3,000-30,000	00.005.652	180-1,697	00.005.665	197-1,857	00.005.678	212-2,008	00.005.691	227-2,145
8,000-60,000	00.005.653	-	00.005.666	-	00.005.679	-	00.005.692	-

Measuring range	Air 8 bar		HCl 30-33%		NaOH 30%		NaOH 50%	
H <sub>2</sub> O l/h	Art. No.	N m <sup>3</sup> /h	Art. No.	l/h	Art. No.	l/h	Art. No.	l/h
50-500	00.005.693	4.5-42	00.005.539	20-405	00.005.552	4-226	00.005.565	1-55
100-1,000	00.005.694	7.5-87	00.005.540	55-866	00.005.553	15-600	00.005.566	3-192
150-1,500	00.005.695	12-135	00.005.541	90-1,340	00.005.554	30-970	00.005.567	6-365
250-2,500	00.005.696	21-237	00.005.542	165-2,310	00.005.555	70-1,800	00.005.568	15-770
200-2,000	00.005.697	18-174	00.005.543	115-1,660	00.005.556	35-1,240	00.005.569	8-520
300-3,000	00.005.698	27-324	00.005.544	190-3,050	00.005.557	75-2,370	00.005.570	15-1,170
600-6,000	00.005.699	51-522	00.005.545	420-4,900	00.005.558	230-4,000	00.005.571	50-2,270
600-6,000	00.005.700	51-525	00.005.546	430-5,090	00.005.559	240-4,700	00.005.572	55-2,300
1,000-10,000	00.005.701	87-903	00.005.547	750-9,460	00.005.560	475-7,340	00.005.573	140-4,340
1,500-15,000	00.005.702	159-1,215	00.005.548	1,415-11,570	00.005.561	1,030-10,330	00.005.574	420-5,820
2,000-20,000	00.005.703	165-1,635	00.005.549	1,500-17,300	00.005.562	915-11,720	00.005.575	245-7,590
3,000-30,000	00.005.704	240-2,274	00.005.550	2,175-24,120	00.005.563	1,195-16,040	00.005.576	400-11,120
8,000-60,000	00.005.705	-	00.005.551	-	00.005.564	-	00.005.577	-

#### Special scales as requested by the customer

Details required: Medium, spec. weight in g/cm<sup>3</sup>, viscosity in cP or mPas, operating temperature in °C, desired measuring range in l/h.

#### Application instructions for special scales

When applying special scales later, ensure that the marking ◀ on the scale corresponds with the one on the measuring tube.



### Accessories

Limit value contact Z40 min.

Limit value contact Z42 max.

For further information, refer to the separate data sheets.

### Installation and assembly instructions

- Install the flow meter into the pipeline system vertically and without tension.
- Provide an inlet and outlet section, Inlet approx. 10 x DN, outlet approx. 5 x DN.

### Notes on operation

- Avoid pressure surges, as these can damage the unit.
- Exercise caution when installing. The measuring tube must not come into contact with solvent.
- Before start-up, make sure that the connected parts are sufficiently tightened.
- The union nuts must not be mixed up on a measuring tube made from the material PVDF. The overall length also does not correspond to the dimensions table.

We reserve the right to make technical changes in the interest of improvement.

### Special scales H<sub>2</sub>O with other units of measurement

Measuring range Series M 335 / M 350					
d mm	DN mm	l/h	l/min	m <sup>3</sup> /h	US GPM
32	25	50–500	0.8–8	0.05–0.5	0.22–2.2
32	25	100–1,000	1.7–17	0.1–1	0.44–4.4
40	32	150–1,500	2.5–25	0.15–1.5	0.66–6.6
40	32	250–2,500	4–41	0.25–2.5	1.1–11
50	40	200–2,000	3.3–33	0.2–2	0.66–6.6
50	40	300–3,000	5–50	0.3–3	1.32–13.2
50	40	600–6,000	10–100	0.6–6	2.64–26.4
63	50	600–6,000	10–100	0.6–6	2.64–26.4
63	50	1,000–10,000	16–166	1–10	4.4–44.02
63	50	1,500–15,000	25–250	1.5–15	6.6–66.04
75	65	2,000–20,000	33–330	2–20	8.8–88
75	65	3,000–30,000	50–500	3–30	13.2–132
75	65	8,000–60,000	133–1,000	8–60	35.2–264

### Pressure corr. table for gases: Calibration pressure 0 bar

Operating pressure bar	Factor x display value	Operating pressure bar	Factor x display value
0.0	1.000	3.0	2.000
0.2	1.095	4.0	2.240
0.4	1.184	5.0	2.450
0.6	1.265	6.0	2.650
0.8	1.340	7.0	2.830
1.0	1.414	8.0	3.000
1.5	1.580	9.0	3.165
2.0	1.730	10.0	3.320

This table is used to correct values displayed for gases by the flow meter if the operating pressure deviates from the pressure used as a basis for the calibration. The values displayed on the flow meter are simply multiplied by the factor corresponding to the operating pressure.

We supply special scales for operating pressures of between 1 and 8 bar (see Page 10).

## Flow meter M123

Measuring ranges 15 – 1,000 l/h

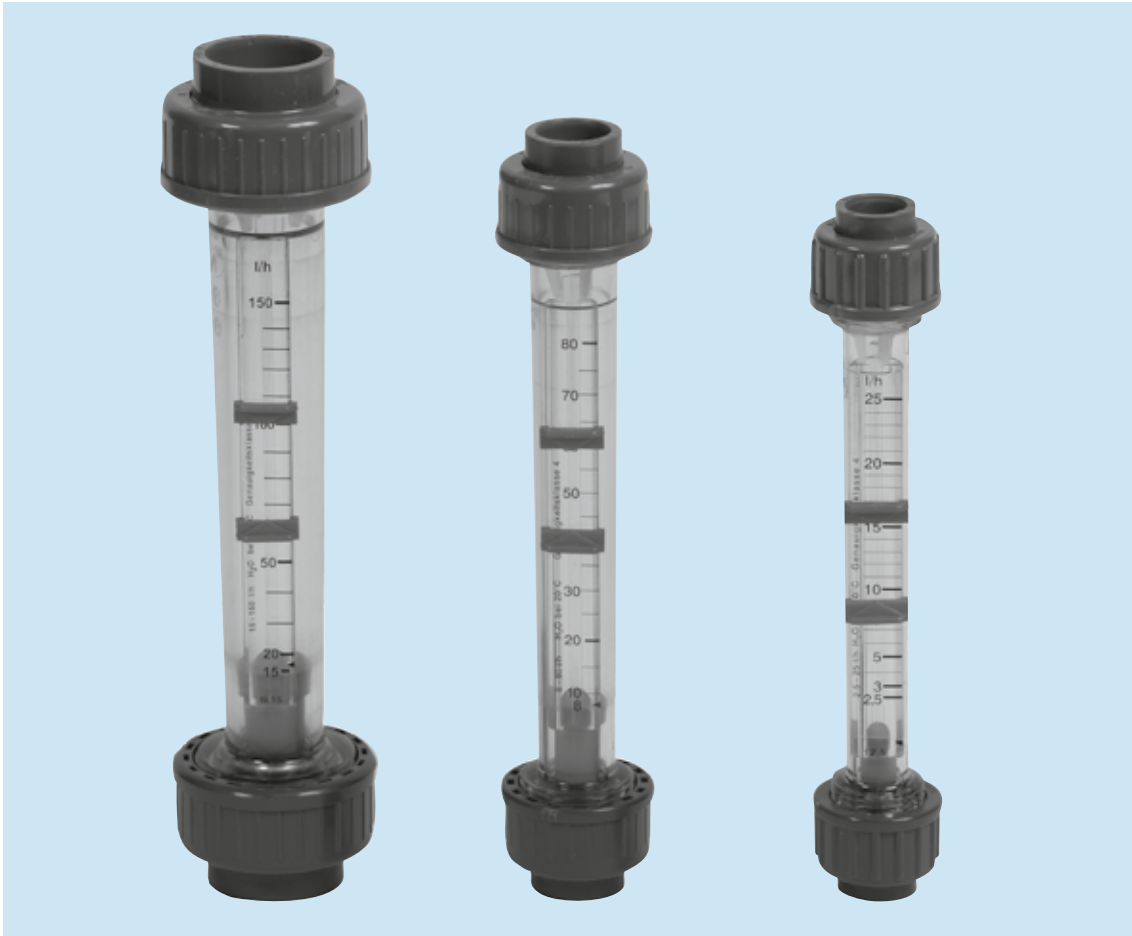

### Function

The FRANK M123 flow meter works on the float principle and is used to measure the flow rate in closed pipelines. The medium flows through the vertically installed flow meter from bottom to top. This raises the float and shows the current flow rate on the scale on the measuring device. The read-off edge corresponds to the largest diameter of the float.

FRANK M123 flow meters have a water scale and 2 setpoint indicators as standard.

### Special features:

- Fracture-proof and corrosion-resistant
- Radially removable
- Adhesive special scales, for liquid and gaseous media
- Holder for accessories (limit value contacts)
- Measuring tube carries the DN label, and also the measuring range and material
- PVDF floats and stops as standard
- Measuring ranges 1.5 – 1,000 l/h
- Less space required thanks to short overall length

### Materials

Measuring tube	max. temp. at 1 bar	Float	Insert, top and bottom	O-ring
PVC	+ 60 °C	PVDF	PVDF	EPDM
PSU	+ 100 °C			FPM
PVDF	+ 140 °C			

### Connection possibilities

Socket	Spigot	Plastic female thread	Metal female thread
PVC adhesive socket (standard)	PP fusion spigot	PVC	Stainless steel V4A
PP fusion socket	PVDF fusion spigot	PP	Malleable cast iron
PVDF fusion socket	PE fusion spigot	PVDF	

### Pressure loss

Water l/h	1.5-15	2.5-25	5-50	10-100	8-80	15-150	20-200	15-150	30-300	50-500	100-1,000
Pressure loss (mm WC)	46.0	46.0	46.0	46.0	44.7	44.7	44.7	82.8	82.8	82.8	82.8

Operating pressure: max. PN 10 at 20 °C

### Measuring accuracy Accuracy Class 4 as defined by VDE/DIN 3513 Page 2

Flow in %	10	20	30	40	50	60	70	80	90	100
Total measured value error in %	13.00	8.00	6.33	5.50	5.00	4.67	4.43	4.25	4.11	4.00
Total limit value error in %	1.3	1.6	1.9	2.2	2.5	2.9	3.1	3.4	3.7	4.0

### Article numbers

da	DN	Measuring tube Measuring range l/h	PVC		PSU		PVDF	
			Float PVDF Art. No.	Float PVDF Mag. Art. No.	Float PVDF Art. No.	Float PVDF Mag. Art. No.	Float PVDF Art. No.	Float PVDF Mag. Art. No.
16	10	1.5-15	17.003.700	17.003.711	17.000.862	17.001.459	17.003.610	17.003.621
16	10	2.5-25	17.003.701	17.003.712	17.000.864	17.001.461	17.003.611	17.003.622
16	10	5-50	17.003.702	17.003.713	17.000.866	17.001.463	17.003.612	17.003.623
16	10	10-100	17.003.703	17.003.714	17.000.868	17.001.465	17.003.613	17.003.624
20	15	8-80	17.003.704	17.003.715	17.000.895	17.001.467	17.003.614	17.003.625
20	15	15-150	17.003.705	17.003.716	17.000.897	17.001.469	17.003.615	17.003.626
20	15	20-200	17.003.706	17.003.717	17.000.899	17.001.471	17.003.616	17.003.627
32	25	15-150	17.003.707	17.003.718	17.000.901	17.001.473	17.003.617	17.003.628
32	25	30-300	17.003.708	17.003.719	17.000.903	17.001.475	17.003.618	17.003.629
32	25	50-500	17.003.709	17.003.720	17.000.905	17.001.477	17.003.619	17.003.630
32	25	100-1,000	17.003.710	17.003.721	17.000.907	17.001.479	17.003.620	17.003.631

### Individual parts

Pos.	Designation	Qty.	Material
1	Measuring tube	1	PSU, PVC, PVDF
2	Float	1	PVDF
3	Insert, top	2	PVDF
4	Union nut	2	PVC, PP, PVDF
5	Insertion part	2	PVC, PP, PVDF
6	O-ring	2	EPDM, FPM
7	Setpoint indicator	2	PS

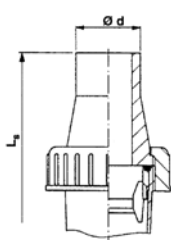

Screw connection with fusion spigot

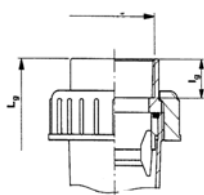

Screw connection with threaded socket

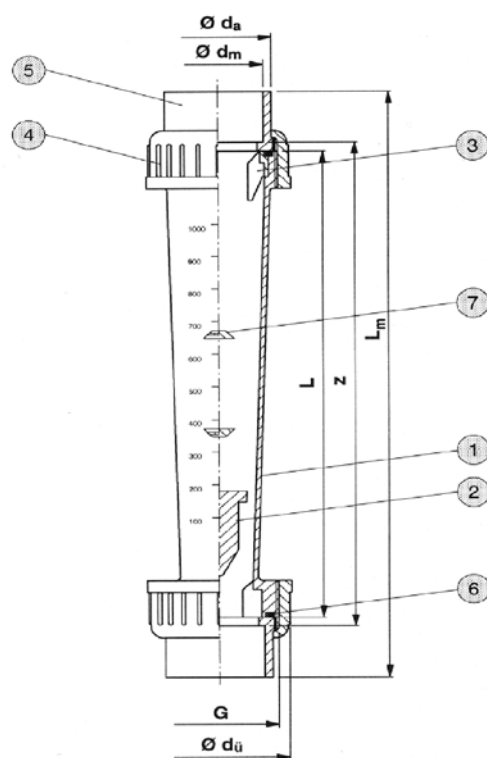

### Dimensions and weights

Measuring range l/h H <sub>2</sub> O	Dimensions in mm																Weight in kg/unit
	DN	d <sub>u</sub>	G	L	Adhesive socket			Fusion socket			Spigot PP			Threaded socket			
					d <sub>m</sub>	z	L <sub>m</sub>	d <sub>m</sub>	z	L <sub>m</sub>	d	L <sub>s</sub>	s	d <sub>g</sub>	L <sub>g</sub>	l <sub>g</sub>	
1.5-15 2.5-25 5-50 10-100	10	35	3/4"	165	16	171	199	15.5	175	201				3/8"	199	11	0.08
8-80 15-150 20-200	15	43	1"	185	20	191	223	19.5	195	223	20	293	1.9	1/2"	223	13	0.13
15-150 30-300 50-500 100-1,000	25	60	1 1/2"	200	32	206	250	31.5	210	246	32	320	3.0	1"	250	17	0.24

**Special scales**

Measuring range	Air 0 bar		Air 1 bar		Air 2 bar		Air 3 bar	
	H <sub>2</sub> O l/h	Art. No.	N m <sup>3</sup> /h	Art. No.	N m <sup>3</sup> /h	Art. No.	N m <sup>3</sup> /h	Art. No.
1.5-15	00.000.998	0.10-0.55	00.001.050	0.15-0.80	00.001.051	0.17-0.9	00.001.052	0.20-1.1
2.5-25	00.001.059	0.2-0.95	00.001.060	0.25-1.3	00.001.061	0.3-1.6	00.001.062	0.4-1.9
5-50	00.001.070	0.5-1.9	00.001.071	0.7-2.7	00.001.072	0.8-3.4	00.001.073	1.0-3.8
10-100	00.001.081	0.8-3.0	00.001.082	1.0-4.2	00.001.083	1.2-5.4	00.001.084	1.4-6.4
8-80	00.001.092	0.6-2.8	00.001.093	0.8-4	00.001.094	1.0-5.0	00.001.095	1.2-5.6
15-150	00.001.103	1.4-5.6	00.001.104	2-8	00.001.105	2-10	00.001.106	3-12
20-200	00.001.114	1.5-7.0	00.001.115	2-10	00.001.116	3-13	00.001.117	3-15
15-150	00.001.125	1.0-6.5	00.001.126	1-9	00.001.127	1.5-11	00.001.128	2-13
30-300	00.001.136	1.5-11	00.001.137	2-15	00.001.138	2.5-18	00.001.139	3-22
50-500	00.001.147	3-18	00.001.148	4-25	00.001.149	5-30	00.001.150	5-35
100-1,000	00.001.158	6-30	00.001.159	8-44	00.001.160	10-54	00.001.161	12-62

Measuring range	Air 4 bar		Air 5 bar		Air 6 bar		Air 7 bar	
	H <sub>2</sub> O l/h	Art. No.	N m <sup>3</sup> /h	Art. No.	N m <sup>3</sup> /h	Art. No.	N m <sup>3</sup> /h	Art. No.
1.5-15	00.001.053	0.25-1.20	00.001.054	0.25-1.3	00.000.999	0.26-1.45	00.001.055	0.30-1.5
2.5-25	00.001.063	0.4-2.1	00.001.064	0.5-2.4	00.001.065	0.5-2.5	00.001.066	0.5-2.7
5-50	00.001.074	1.2-4.2	00.001.075	1.2-4.6	00.001.076	1.2-5.0	00.001.077	1.4-5.4
10-100	00.001.085	1.6-7.0	00.001.086	1.6-7.4	00.001.087	2.0-8.0	00.001.088	2-8.8
8-80	00.001.096	1.4-6.4	00.001.097	1.4-7.0	00.001.098	1.5-7.5	00.001.099	1.5-8.0
15-150	00.001.107	3-13	00.001.108	3-14	00.001.109	3.5-15	00.001.110	3.5-16.5
20-200	00.001.118	4-17	00.001.119	4-18	00.001.120	4-20	00.001.121	5-21
15-150	00.001.129	2-14.5	00.001.130	2-16	00.001.131	2-17	00.001.132	2.5-18
30-300	00.001.140	3-24	00.001.141	4-26	00.001.142	4-28	00.001.143	4-30
50-500	00.001.151	6-40	00.001.152	6-44	00.001.153	8-48	00.001.154	8-50
100-1,000	00.001.162	12-70	00.001.163	15-75	00.001.164	15-80	00.001.165	15-85

Measuring range	Air 8 bar		Air 9 bar		Air 10 bar	
	H <sub>2</sub> O l/h	Art. No.	N m <sup>3</sup> /h	Art. No.	N m <sup>3</sup> /h	Art. No.
1.5-15	00.001.056	0.3-1.6	00.001.057	0.3-1.7	00.001.058	0.35-1.8
2.5-25	00.001.067	0.6-2.9	00.001.068	0.6-3.0	00.001.069	0.6-3.2
5-50	00.001.078	1.4-5.8	00.001.079	1.6-6.0	00.001.080	1.6-6.4
10-100	00.001.089	2.0-9.0	00.001.090	2-10	00.001.091	2-10
8-80	00.001.100	1.5-8.5	00.001.101	2.0-9.0	00.001.102	2.0-9.5
15-150	00.001.111	4-17	00.001.112	4-18	00.001.113	4-19
20-200	00.001.122	5-23	00.001.123	5-23	00.001.124	5-25
15-150	00.001.133	2.5-19.5	00.001.134	3-20	00.001.135	3-21
30-300	00.001.144	4-33	00.001.145	5-34	00.001.146	5-35
50-500	00.001.155	8-54	00.001.156	8-56	00.001.157	10-60
100-1,000	00.001.166	20-90	00.001.167	20-95	00.001.168	20-100

### Special scales

Measuring range	HCl 30-33% (PSU)		NaOH 30%		NaOH 50%	
	Art. No.	N m <sup>3</sup> /h	Art. No.	N m <sup>3</sup> /h	Art. No.	N m <sup>3</sup> /h
1.5-15	00.005.117	1-10	00.005.144	0.1-2.0	-	-
2.5-25	00.005.118	2.5-20	00.005.145	0.2-5	-	-
5-50	00.005.119	5-40	00.005.128	1-14	-	-
10-100	00.005.120	10-85	00.005.129	3-35	-	-
8-80	00.005.121	8-70	00.005.130	2-23	00.005.137	0.2-3.5
15-150	00.005.122	15-125	00.005.131	3-55	00.005.138	0.5-10
20-200	00.005.123	20-170	00.005.132	5-80	00.005.139	0.5-16
15-150	00.005.124	15-125	00.005.133	3-55	00.005.140	0.5-11
30-300	00.005.125	30-260	00.005.134	6-130	00.005.141	1-33
50-500	00.005.126	50-425	00.005.135	10-250	00.005.142	2-80
100-1,000	00.005.127	100-850	00.005.136	40-600	00.005.143	10-220

#### Special scales as requested by the customer

Details required: Medium, spec. weight in g/cm<sup>3</sup>, viscosity in cP or mPas, operating temperature in °C, desired measuring range in l/h.

#### Application instructions for special scales

When applying special scales later, ensure that the marking ◀ on the scale corresponds with the one on the measuring tube.

#### Accessories

Limit value contact Z40  
Limit value contact Z42

#### Installation and assembly instructions

- Install the flow meter into the pipeline system vertically and without tension.
- Provide an inlet and outlet section  
Inlet approx. 10 x DN, outlet approx. 5 x DN.

#### Notes on operation

- Avoid pressure surges, as these can damage the unit.
- Exercise caution when installing. The measuring tube must not come into contact with solvent.
- Before start-up, make sure that the connected parts are sufficiently tightened.
- The union nuts must not be mixed up on a measuring tube made from the material PVDF. The overall length also does not correspond to the dimensions table.

We reserve the right to make technical changes in the interest of improvement.

#### Special scales H<sub>2</sub>O with other units of measurement

l/h	Series M 123	
	USGPM	Imp. Gal/h
1.5-15	0.006-0.066	0.32-3.2
2.5-25	0.01-0.11	0.54-5.4
5-50	0.02-0.2	1.09-10.9
10-100	0.04-0.44	2.19-21.9
8-80	0.035-0.35	1.75-17.5
15-150	0.06-0.66	3.3-33
20-200	0.08-0.8	4.4-44
30-300	0.13-1.3	6.6-66
50-500	0.22-2.2	11-110
100-1,000	0.44-4.4	22-220

## Limit value contact Z 40 min. and Z 42 max.

For float-type flow meters M 335 / M 350 / M 123

### Use

The limit value contacts Z 40 and Z 42 are used for external monitoring of limited flow values on our float-type flow meters. They are pushed onto the guide located on the flow measuring device and can be set to any desired value of the corresponding scale.

### Function

A solenoid installed in the float closes or opens a reed contact permanently cast in the limit value contact. The switching function is bistable. This means that the switching state is maintained even if the solenoid float moves away from the contact.

### Switching states

	Float above	Float below
Z 40 min	open	closed
Z 42 max	closed	open

### Attention

When retrofitting limit value contacts, ensure that the standard float is replaced with a solenoid float. The solenoid float is clearly identified by a "M" on the top.

### Technical data

Switching voltage*	max. 230 V~
Switching rating*	max. 10 W/12 VA
Switching current*	max. 0.5 A
Contact resistance	< 200 mOhm
Leakage resistance	> 10 <sup>11</sup> Ohm
Permissible ambient temperature	0 to +55 °C
Protection type	in acc. with DIN 40050-IP 65
Switching hysteresis	1-2 mm float travel

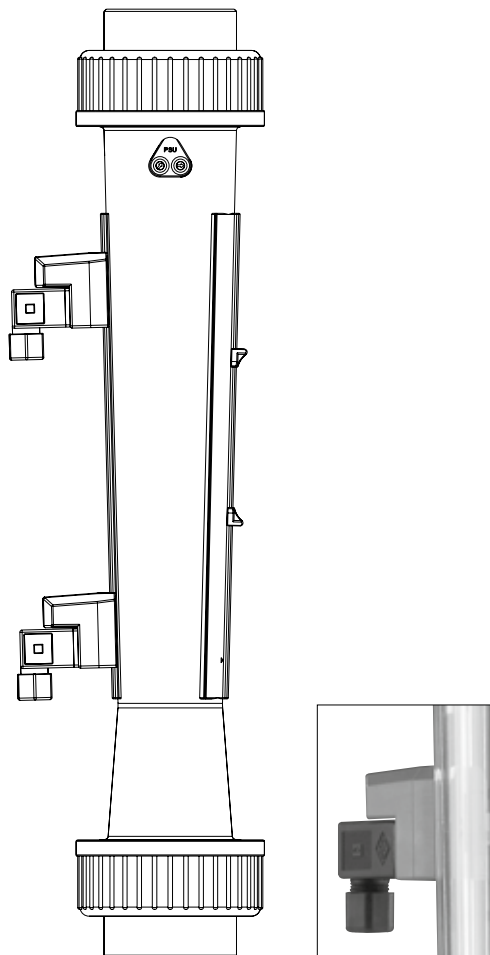

### Order numbers

Z 40 min.	17.100.686
Z 42 max.	17.100.687

We reserve the right to make technical changes in the interest of improvement.

\* Even a brief overshoot is not permitted. This is uncontrollable with inductive or capacitive peaks, e.g. with contactors or solenoid valves. It is therefore recommended to use a limit value switch or a contact protection relay.

**PMMA flow meter M10 to M13**  
Measuring ranges 1.5 – 100 l/h H<sub>2</sub>O

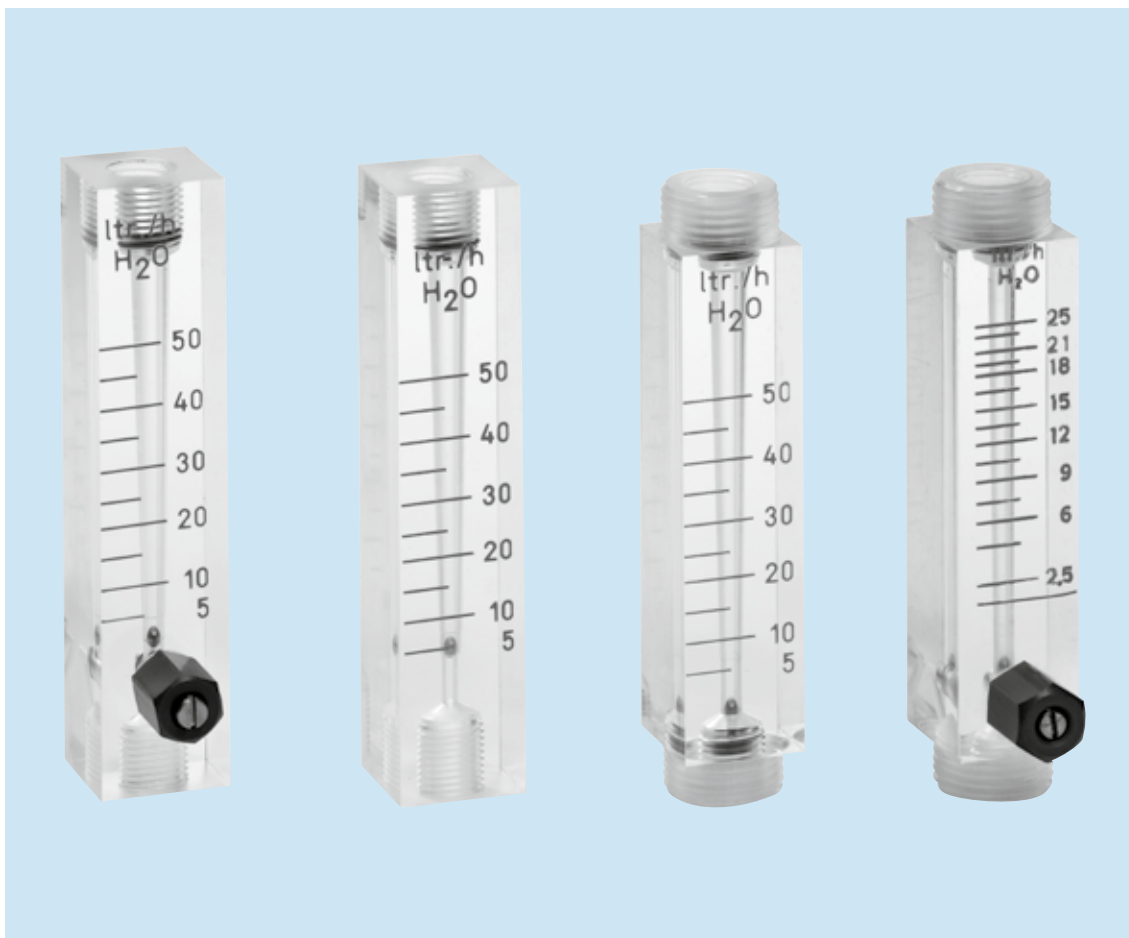

**Function**

FRANK M10 to M13 flow meters work on the float principle and are used to measure the flow rate in closed pipelines. The medium flows through the vertically installed flow meter from bottom to top. This raises the float and shows the current flow rate on the scale on the measuring device. The read-off edge corresponds to the largest diameter of the float (ball).

**Operating pressure:** max 10 bar at 20 °C

**Special features:**

- Compact and robust design
- Short overall length
- With needle valve (M10 and M13), very fine adjustment

**Materials**

Designation	Material
Housing	PMMA (Plexiglas)
Float	Ball Va 1.4571
Flow control	PVC/Va 1.4571
O-ring (control)	EPDM or FPM



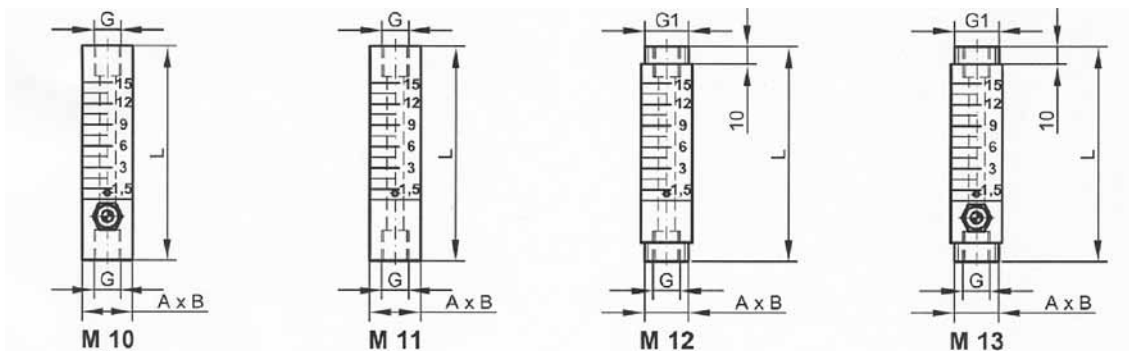

Measuring range H <sub>2</sub> O l/h	Measuring range air l/h, o bar	A x B	L	G	G1	M 10 with control	M 11	M 12	M 13 with control
1.5-15	100-700	25 x 25	105	R 1/4"	R 5/8"	17.001.584	17.001.588	17.001.596	17.001.620
2.5-25		25 x 25	120	R 1/4"	R 5/8"	17.001.565	17.001.589	17.001.597	17.001.621
5-50	100-2,000	25 x 25	120	R 1/4"	R 5/8"	17.001.566	17.001.590	17.001.598	17.001.622
10-100		25 x 25	120	R 1/4"	R 5/8"	17.001.567	17.001.591	17.001.599	17.001.623



---

FRANK plastic AG  
Herbert-Frank-Straße 26  
D-72178 Waldachtal  
Telefon +49 (0) 7486 181 0  
Fax +49 (0) 7486 181 337  
E-Mail [info@frankplastic.de](mailto:info@frankplastic.de)  
[www.frankplastic.de](http://www.frankplastic.de)

