

Constant Flow Valves

Specifications

Sizes: PVC: 1/2", 3/4", 1", 2", 3", 4"

Body: PVC

Bonnet: PVC

Models: Flanged ANSI

Seals: EPDM

Springs: Stainless Steel 304 with PCTFE Coating

Temperature: 30° - 120° F

Standard Features (Sizes 1/2" - 4")

- Body and bonnet are of solid PVC
- All wetted parts are of thermoplastic and elastomeric materials for superior corrosion resistance
- A preset constant flow rate is maintained by automatically regulating orifice opening area, responding to changes of pressure differentials across the valve - see "Principles of Operation " on the following page
- Vertical or horizontal installations
- Flow rate accuracy: Plus or minus six percent of full scale flow rate (water at ambient temperature)
- Flow rate rangeability: 20 : 1 maximum
- Handwheel permits on/off opening and closing
- Handwheel serves as a mechanism by which the flow rate setting may be adjusted without shutting down the pipeline
- Springs of stainless steel 304 with PCTFE coating tested for long cycle life
- Prescribed flow setting is clearly visible on the indicator at the top

Sample Specification

All constant flow valves shall be of solid thermoplastic flanged construction, and all wetted parts shall be of non-metallic materials. Size 1/2" and 3/4" shall be of inline design, while 1" - 4" shall be a "Y" type design. PVC shall conform to ASTM D1784 Cell Classification 12454-A. Spring construction shall be 304 stainless steel with PCTFE coating. All constant flow valves shall have a calibrated flow dial and position indicator. Valve accuracy shall be plus or minus six percent of full scale. Constant flow valve sizes 1/2" - 3" shall have a maximum upstream pressure range of 150psi at 120° F and size 4" 70psi at 120° F, as manufactured by Asahi/America, Inc.

*Consult factory

TYPE	SIZES	CHARACTERISTICS
A	1", 2" 3"	Fluid flows through the valve
B	1/2", 3/4", 1", 2", 3" ,	Flow rate setting range is large (small to large flow rate)
C	1/2", 3/4", 1", 2", 3", 4"	Lines with large pressure differentials (upstream vs. downstream)
D	3", 4"	High flow rate

TYPE A (1" - 3")

FLOW →

TYPE B (1/2" - 3")
TYPE C (1/2" - 4")
TYPE D (3" - 4")

← FLOW

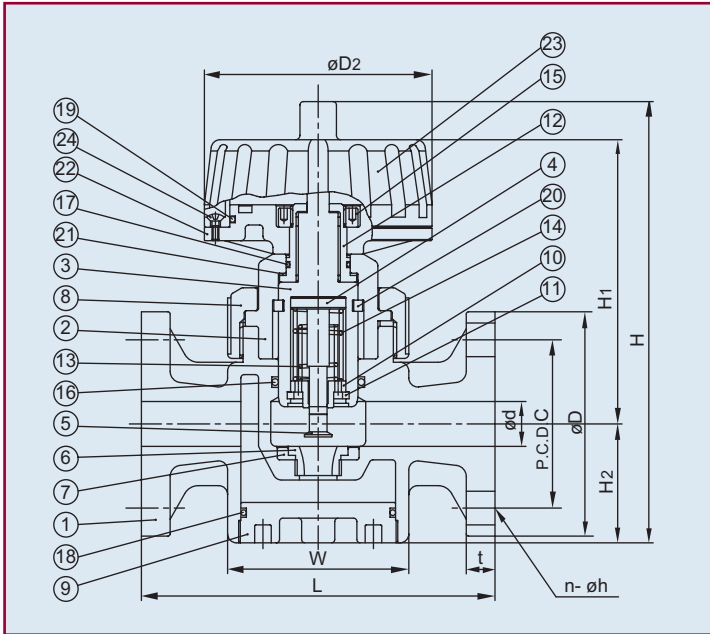

Parts List (Sizes 1/2" – 3/4")

PARTS			
NO.	DESCRIPTION	PCS.	MATERIAL
1	Body	1	PVC
2	Bonnet	1	PVC
3	Cylinder	1	PVC
4	Piston	1	PVC
5	Plug	1	PVC
6	Orifice	1	PVC
7	Seat	1	EPDM
8	Cap Nut	1	PVC
9	Cap	1	PVC
10	Spring Base	1	PVC
11	Stop Ring	1	PVDF
12	Sleeve	1	Copper Alloy
13	Spring [A]	1	Stainless Steel 304
14	Spring [B]	1	Stainless Steel 304
15	Nut	1	PVC
16	O-Ring [A]	1	EPDM
17	O-Ring [B]	1	EPDM
18	O-Ring [C]	1	EPDM
19	O-Ring [D]	1	EPDM
20	Key	2	PP
21	Thrust Ring	1	PP
22	Handle Base	1	PVC
23	Handle Cover	1	PVC
24	Screw	4	Stainless Steel 304

* With PCTFE coating

Principles of Operation

1. When the upstream fluid pressure, P1, is introduced at the flow control orifice, it exerts a responding pressure on the upper surface of the flange on the piston type valve plug.
2. Likewise, the downstream pressure, P2, exerts a corresponding pressure to the lower surface of the valve plug flange.
3. Thus, when a differential exists between the fluid upstream and downstream of the orifice, the corresponding differential pressure acting on the surfaces of the flange moves the valve plug piston either downward against the force of the spring cartridge or upward by the force of the spring, depending upon the direction of the force induced by the existing differential pressure.
4. This upward or downward movement of the valve plug piston causes the flow orifice to be widened or narrowed accordingly, thus the flow rate of the fluid passing across the orifice is automatically adjusted. For example, if the differential pressure, (P1 – P2) created between the upstream and downstream sides of the orifice increases, the valve plug piston moves downward to narrow the area of the orifice opening and automatically adjusts to the preset flow rate value. The reverse is also true when the differential pressure decreases, piston moves upward increasing the orifice opening area and allowing the fluid flow rate to increase to the preset value.

Dimensions (Sizes 1/2" – 3/4") (in.)

NOMINAL SIZE		d	D	c	n	h	L	t
INCHES	mm							
1/2	15	0.63	3.50	2.38	4	0.62	6.30	0.47
3/4	20	0.79	3.88	2.75	4	0.62	6.30	0.51

NOMINAL SIZE		W	D2	H	H1	H
INCHES	mm					
1/2	15	3.23 X 3.23	4.06	7.76	5.08	2.01
3/4	20	3.23 X 3.23	4.06	7.76	5.00	2.09

NOTE: THE PISTON FOR TYPE B, C AND D DOES NOT HAVE INLET FLUID PASSAGE. THE PRESSURE DIFFERENTIAL,

(P1 – P2), EXERTS DIRECTLY ON THE PLUG SURFACE.

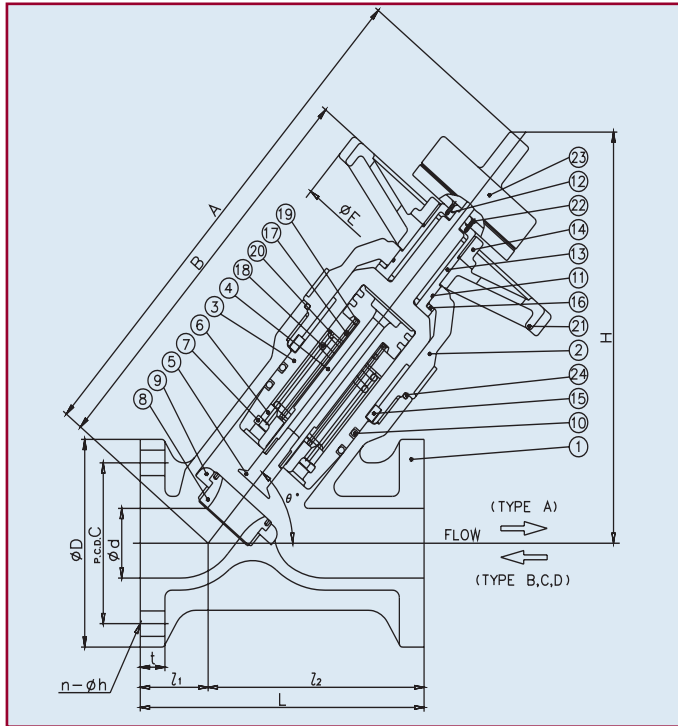

Preset Flow Rates (AND WORKING DIFFERENTIAL PRESSURE)

NOMINAL SIZE		TYPE	FLOW RATE	RANGEABILITY	WORKING DIFFERENTIAL PRESSURE
INCHES	mm		GAL./MIN.		PSI
1/2	15	B	0.176 - 3.52	20:1	2.85 - 14.22
		C	0.35 - 3.52	10:1	4.27 - 28.45
3/4	20	B	0.26 - 5.28	20:1	2.85 - 14.22
		C	0.53 - 5.28	10:1	4.27 - 28.45
1	25	A	2.20 - 8.81	4:1	2.85 - 14.22
		B	0.441 - 8.81	20:1	2.85 - 14.22
		C	0.881 - 8.81	10:1	4.27 - 28.45
2	50	A	8.81 - 35.22	4:1	2.85 - 14.22
		B	1.76 - 35.22	20:1	2.85 - 14.22
		C	3.52 - 35.22	10:1	4.27 - 28.45
3	80	A	22.02 - 88.07	4:1	4.85 - 14.22
		B	4.403 - 88.07	20:1	2.85 - 14.22
		C	8.81 - 88.07	10:1	4.27 - 28.45
		D	66.04 - 132.10	2:1	4.27 - 21.33
4	100	C	44.03 - 264.20	6:1	4.27 - 28.45
		D	132.10 - 264.20	2:1	2.85 - 21.33

Parts List (Sizes 1" - 4")

PARTS			
NO.	DESCRIPTION	PCS.	MATERIAL
1	Body	1	PVC
2	Bonnet	1	PVC
3	Cylinder	1	PVC
4	Piston	1	PVC
5	Plug	1	PVC
6	Spring Base	1	PVC
7	Stop Ring	1	PVDF
8	Orifice	1	PVC
9	Seat	1	EPDM
10	O-Ring (A)	1	EPDM
11	O-Ring (B)	1	EPDM
12	O-Ring (C)	1	EPDM
13	Sleeve	1	Copper Alloy
14	Cap	1	PVC
15	Key	1	PVC
16	Thrust Ring	1	PP
17	Spring (A)	1	Stainless Steel 304*
18	Spring (B)	1	Stainless Steel 304*
19	Washer (A)	1	PVC
20	Washer (B)	2	PVC
21	Handle Wheel	1	PP
22	Screw	1	Copper Alloy
23	Lift Indicator	1	PVC
24	O-Ring (D)	1	EPDM

* With PCTFE coating

Weight (lbs.)

NOMINAL SIZE		WT (Lbs.)
INCHES	mm	
1/2	15	3.31
3/4	20	3.31
1	25	3.31
2	50	11.02
3	80	18.74
4	100	36.38

Constant Flow Valves

Dimensions (Sizes 1" – 4") (in.)

NOMINAL SIZE		ANSI CLASS 150					/1	/2	L	t	A	B	H	E	Degree
INCHES	mm	d	D	C	n	h									
1	25	0.98	4.25	3.12	4	0.62	1.57	4.72	6.30	0.55	10.71	7.91	8.58	5.91	50
2	50	2.05	6.00	4.75	4	0.75	2.17	6.89	9.06	0.79	15.35	12.17	12.09	8.27	50
3	80	3.07	7.50	6.00	4	0.75	2.76	8.27	11.02	0.87	19.06	15.24	14.84	8.27	50

NOMINAL SIZE		ANSI CLASS 150					/1	/2	L	t	A	B	H	E	Degree
INCHES	mm	d	D	C	n	h									
4	100	3.94	8.66	7.50	8	0.75	3.35	12.4	15.75	0.87	24.53	19.02	17.56	9.84	50

Caution

- Constant flow valves are intended for "clean fluid" services. Should the possibility of foreign matters exist in the media, a sediment strainer of 60 mesh is to be installed in the upstream of the valve. For added protection, avoid installing valves with bonnet facing downward, regardless of vertical or horizontal installation.
- For the utmost functional accuracy, the following conditions apply:
 1. Media specific gravity: Sizes 1/2" - 3" up to 1.4, sizes 4" up to 1.1
 2. Media viscosity: Maximum 30 cp
 3. Working pressures are grouped into four that correlate to working temperatures per the format below.
- For size 4", maximum upstream working pressure is 70psi.
- Make sure the "flow direction" is clearly marked on the valve body before installation.
- Note that flow direction of Type A is different from that of Type B, C and D.
- The valve can be installed either vertically or horizontally, as long as fluid always fills the valve fluid passage.
- Never operate the valves when indicator is out of the gauge range.
- Never attempt to disassemble indicator unit at the top (preset by the factory).
- Never remove valve from pipeline under pressure.
- Always wear protective gloves and goggles.

Tips On Constant Flow Valve

- Keep constant flow rate without power or labor.
- To operate, simply rotate handle clockwise to bring indicator to the designated position.
- Rotate handle clockwise to decrease the flow and counterclockwise to increase.
- To fully close the valve, rotate handle clockwise to bring the indicator to "0" (zero) position.
- To properly set a new flow rate, rotate handle counterclockwise until the indicator goes beyond the intended new rate. Then, reverse (rotate clockwise) to the new rate.
- Indicator must be positioned at "0" (zero) of the gauge, if bonnet is to be disassembled.

The valves are ideal for:

1. Any constant media supply
2. Well-balanced fluid supply in parallel piping systems
3. Simultaneous and even fluid supply to multi-pipelines, multi-tanks, large and small pools

Constant Flow Valves

Available Upstream Pressure Range

(Size 1/2" - 4", Type-A,B,C,D)

BODY MATERIAL		PVC		
TEMPERATURE		35 - 85 F	86 - 105 F	106 - 120 F
UPSTREAM PRESSURE RANGE	0-35psi			
	35-70psi			
	70-110psi			

Max. Allowable Upstream Pressure

- PVC 1/2" - 3"; 0 - 150psi
- PVC 4"; 0 - 70psi

Troubleshooting

What if fluid flows even when valve is fully closed?

1. Either seat or plug is damaged. Replace body or cylinder.
2. Foreign material caught between plug and orifice. Clean seat and plug.

What if valve cannot be closed?

1. Foreign material trapped or built up between plug and orifice. Disassemble and clean.

What if fluid leaks outside?

1. O-ring is chemically attacked or damaged. Replace O-ring.

What if flow is extraordinarily small?

1. Insufficient differential pressure. Adjust differential pressure.
2. Foreign material caught between plug and orifice. Clean.

What if flow rate exceeds the preset range?

1. Differential pressure exceeded the range. Adjust differential pressure.
2. Damaged or worn plug and/or orifice. Consult factory.
3. Foreign material caught between plug and orifice.

Ordering Information

Service Conditions

1. Media: _____ Conc: _____ %
2. Specific Gravity _____ Viscosity _____
3. Line Temperature: Max. _____ (i F)
Line Temperature: Min. _____ (i F)
4. Flow Req'd: Max _____ (gpm)
Min _____ (gpm)
5. Max Line Pressure: Upstream _____ (psi)
Downstream _____ (psi)
6. Min Line Pressure: Upstream _____ (psi)
Downstream _____ (psi)

Valve Specifications

1. Line Size: _____
2. Type: _____
3. Temp. Range: _____
4. Pres. Range: _____
5. Seal Material: _____
6. Connection: _____

NOTE: CONSTANT FLOW VALVES ARE SPECIAL ORDERED FROM JAPAN AND CAN NOT BE ORDERED WITHOUT CUSTOMER PROVIDED SERVICE CONDITIONS

Constant Flow Valves

1.0 Scope:

All requirements are for PVC Constant Flow Valves.

2.0 Materials:

U-PVC – Conforming to ASTM D1784 Cell Classification 12454 A

EPDM – Ethylene Propylene Diene Terpolymer Rubber

FKM – Viton® Fluorocarbon Rubber

ECTFE – Ethylene/Chlorotrifluoroethylene

3.0 Valves:

All Constant Flow Valves shall be of solid thermoplastic flanged body construction. 1/2" – 3/4" shall be inline design while 1" – 4" shall be Y type design. All Constant Flow valves shall have a calibrated flow dial and position indicator. Valve accuracy shall be +/- 6% of full scale. Internal valve spring shall be 304 SS with ECTFE coating.

3.1 Operators

Handwheel operator Asahi Standard valve handle Red color.

3.2 Approved Manufacturer

Valves shall be provided by Asahi/America, Inc. of Lawrence, MA with no approved equals. Manufacturer must be ISO-9001 certified.

3.3 Pressure Vs. Temperature

Valves shall have a pressure rating of: 150 psi at 70° F all sizes

4.0 Accessories:

4.1 Actuation

There is no actuation available for the Constant Flow Valves.

5.0 Installation Procedures:

All valve joints shall be flanged and shall be prepared according to the instructions detailed in the Constant Flow Valve O & M manual. All accessories should be installed in accordance with the manufacturer's requirements as well as any facility requirements.